

300 Series AFCO-Rail Stair Rail









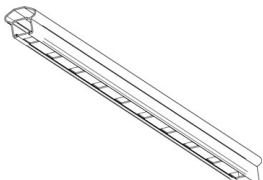
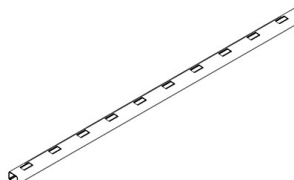

INSTALLATION INSTRUCTIONS

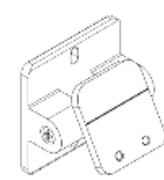
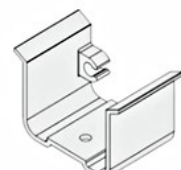

AFCO
Columns and Railings
a Division of AFCO Industries, Inc.

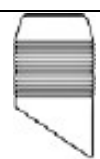
PARTS INCLUDED:

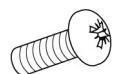
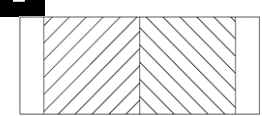
TOP RAIL (1)	BOTTOM RAIL (1)	TOP RAIL HINGE ASSEMBLY (2)	BOTTOM RAIL HINGE ASSEMBLY (2)
A 	B 	C 	D 
SADDLE BRACKETS (2)	SADDLE BRACKET COVER (2)	BOTTOM BRACKET (2)	7" SUPPORT BLOCK (1)
E 	F 	G 	H 
SUPPORT BLOCK CONNECTORS (2)	#10 x 1" SELF DRILLING SCREWS (8 COLOR MATCHED, 4 MILL FINISH)	#10 -24 x 7/16 MACHINE SCREWS (8)	ADHESIVE TAB
I 	J 	K 	L 

300 SERIES AFCO-RAIL ADJUSTABLE RAIL

TOOLS REQUIRED:

Drill bit 5/32" (.156")
T25 Torx Driver (minimum 2") & Bit Holder
Drill (with adjustable clutch, recommended)
Miter Saw (with metal cutting blade)
Level
Rubber Mallet
Tape Measure
Touch-up paint

NOTES:

- Post and balusters packaged separately.

FOR A SUCCESSFUL INSTALLATION:

- Read the instructions completely before beginning the installation.
- Plan your railing project. Sketch your project with the actual measurements of your deck or balcony complete with post locations.
- Check local building codes to ensure compliance.
- Check carton(s) to determine part count is complete.
- After cutting rails, balusters, or posts, paint exposed metal for maximum protection against the elements.
- Installation is best accomplished with two people.
- Wear personal protection equipment, safety glasses, etc.
- Use care not to over-torque the screws. Pre-drilling is recommended.
- **Provided hardware to install AFCO-Rail is for use with Aluminum AFCO-Rail posts. If installing to other surfaces the installer must acquire the appropriate hardware as needed for proper installation.**

POSTS INSTALLATION:

1. Determine the location and position of the upper and lower post based on the project layout. Mark the desired location of the posts.
 To ensure post location is compatible with railing prior to securing to the deck surface, place both posts in position, and lay the bottom rail along the stair from top to bottom adjacent to both posts (see photo). On the rail side of the post, measure up from the top of the rail and ensure there is a minimum of 35-1/2" for the 36" rail height and a minimum of 41-1/2" for the 42" rail height to the top of the post. Post location may have to be adjusted to ensure minimum is obtained. Repeat this step for the bottom post.



- For railing mounted 36" high use a 44" post at the bottom of the stairs.
 - For railing mounted 42" high use a 54" post at the bottom of the stairs.
- For a wooden deck position the post so the fasteners will go into the floor joists, and make sure the decking is firmly attached to the joists at the location of the posts. If necessary, use wood blocking as reinforcement underneath the decking where the posts are located.
 Fasteners which hold the brackets to the surface should be able to secure to joist or reinforcement braces, into at least 3" of solid wood.

2. When the final position is determined for the post, mark the hole locations of the four 3/8" diameter mounting holes provided on the base and remove the post assembly. Drill the marked locations into the decking and reinforcement using the proper size drill required for the fasteners being used.

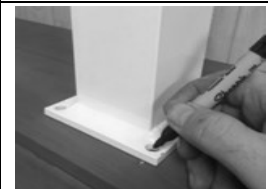

3. Remount the post assembly. Insert the appropriate fasteners then secure the base to the deck structure. Make certain the posts are plumb. If the post requires adjustment, add stainless steel washers under the base plate. Do not re-install the base post trim until step 2 of the rail installation.
Note: When installing AFCO- Rail Post onto treated wood surface, install the provided ACQ pad that is included in the post kit between the post base and the treated surface.



STAIR RAIL INSTALLATION:

1. Lay the Bottom Rail (B) on the stair from top to bottom and adjacent to the posts previously installed. Make a level reference mark with a pencil on the bracket side of both the upper and lower posts at the point where the top of the rail meets the post.
Note: Illustration photo shown is the upper post.



2. Install the base post trim on both the upper and lower posts.

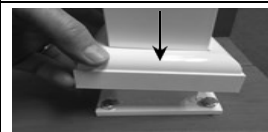

3. Locate the Bottom Rail Hinge Assembly (D) first by measuring up from the reference marks placed on the posts in step 1 based on the chart below and place mark at those locations on the bracket side of the post for the Bottom Hinge Assembly only. This will be the centerline mounting point for the bottom hinge assemblies. (Note: Centerline mark must be a minimum of 2-5/8" from the deck surface to allow space for the base trim to be installed.) From the centerline marks of the Bottom Rail Hinge Assemblies measure up the distance indicated on the chart to locate the centerline of the Top Rail Hinge Assemblies.

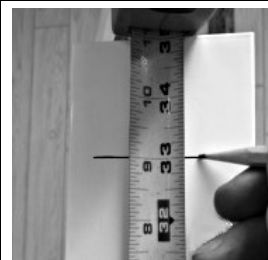

UPPER POST

LOWER POST

	Bottom Rail Hinge	Top Rail Hinge	Bottom Rail Hinge	Top Rail Hinge
36" Rail	Up 1/2"	33"	Up 1-1/2"	33"
42" Rail	Up 1/2"	39"	Up 1-1/2"	39"

4. To locate the mounting hole locations of Top Rail Hinge Assembly (C) and the Bottom Rail Hinge Assembly (D) place a mark 1" above and below each of the level line marks centered on the posts from step 3 (see photo) This will be the location of the fasteners to attach the Hinge Assemblies to the post.

Note: Pre-drilling is recommended at these locations for the fasteners.

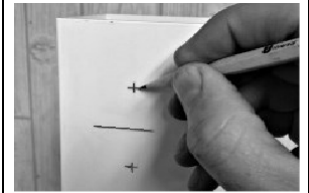

5. Using the Color Matched #10-1" Self-Drilling Screws (J) secure the Top Rail Hinge Assembly (C) and the Bottom Rail Hinge Assembly (D) to the upper and lower posts through the marked and/or pre-drilled hole locations. (Mounting holes are elongated to allow a small amount of adjustment if necessary to properly align the hinge assemble with the rail.)

Note: Two screws are required to mount each bracket to properly secure in place. Depending on the post location, it may be necessary to temporarily remove the post or disassemble the hinge for adequate access to install the fasteners.



6. Attach the Saddle Brackets (E) to the Top Rail Hinge Assembly (C) using the #10-24 x 7/16" Machine Screws (K).

Note: Two screws are required to mount each bracket to properly secure in place.



7. On a flat surface (use the box as a pad to protect painted surfaces), Align the holes of both the Top Rail (A) and the Bottom Rail (B). Place a mark at the determined midpoint of the Bottom Rail (B) (Either baluster on center, or the space between the baluster centered as shown) Transfer that mark to the Top Rail (A).

Note: There must be at least 2" between the cut ends and the center of the first baluster holes for proper clearance of the mounting brackets. Depending on the installation, for best spacing of the first baluster on each end, it may be necessary to shift the center point of the rail from a baluster to a space between two balusters or vice versa.

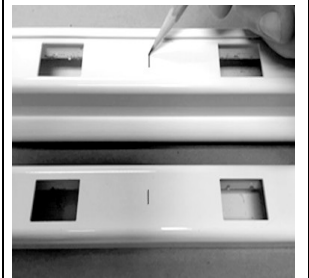

8. From the centerlines marked on both the Top Rail and Bottom Rail in step 7, place a mark 1/2" to the left of the centerline on the Top Rail (A) and 3/8" to the right of the centerline on the Bottom Rail (B). These marked locations will become the new centerline mark of both rails to determine cutting locations.

NOTE: When viewed as the photo shown, the right side of both the Top Rail and Bottom Rail will be installed to the lower side of the stair.

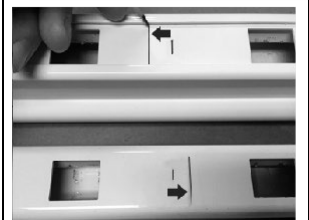

9. To determine rail length measure the distance between the parallel faces of the Bottom Rail hinge assembly brackets installed in step 5. From the new determined centerlines of Top Rail (A), and Bottom Rail (B) completed in steps 7 & 8, measure half the distance of the determined bottom rail length, and place a mark both right and left of the centerlines. This will be the cut marks for the Bottom Rail (B) only. Shorten the Top Rail (A) by an additional 3/8" from each mark previously placed at the ends of the rail to accommodate bracket clearance. This will be the cut marks for the Top Rail (A).

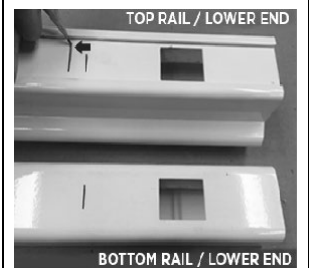

10. Install Support Block Connectors (I) using Mill Finish #10-1" Self-Drilling Screw (J) to the underside of Bottom Rail (B).

Note: One Support Block, cut from Support Block material (H), is recommended for rails measuring 72" in length or less; use two Support Blocks for longer lengths. If one Support Block is required, install Support Block Connector (I) at center point of bottom rail (B). If two Support Blocks are required, install Support Block Connector (I) equal distance from each end of the Bottom Rail (B).



11. To assemble rail, begin with Top Rail (A) and insert balusters into each baluster hole. Use a rubber mallet to tap the balusters into place until fully seated into the Top Rail.

Note: It is recommended to use the box as a pad to prevent scuffing of the painted finish.

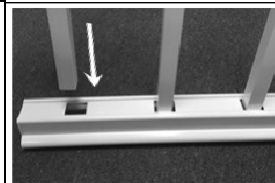

12. Insert balusters in the Bottom Rail (B) the same as in step 1, beginning at one end and working to the opposite end. Stand the assembly upside down on the surface of the box and tap the Bottom Rail (B) with a rubber mallet to secure the balusters in place. Stand assembly upright.

Note: Notches are provided on the front of the box to help align balusters and aid in the assembly of the rail in this step.

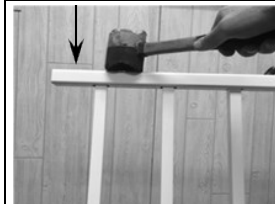

13. Slide Saddle Bracket Covers (F) over each end of the Top Rail (A) at least 3-4" inward over each end of the rail. Covers will be secured in final position later.

Note: A small piece of tape may be required to hold the bracket covers in place.

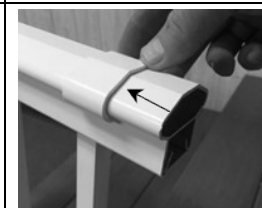

14. Slide Bottom Brackets (G) with the counter bore holes facing down and toward the balusters, over each end of the Bottom Rail (B). A small piece of tape may be required to hold lower bottom brackets in place. Next, set the rail assembly into the Saddle Brackets (E) previously installed (step 6) letting the Bottom Rail (B) hang freely between the posts.



15. At the point(s) where you installed Support Block Connector(s) (step 11), carefully measure the distance from the underside of the bottom rail (B) to the floor or step. Cut support block material (H) to fit. Slip the Support Block(s) over Support Block Connector (s) (I). Slide the rail back into place and make certain the rail is plumb.



16. Slide and hold the Bottom Brackets (G) against the Bottom Rail Hinge Assembly (D) attached to the upper and lower post and secure with the #10-24 x 7/16 Phillips Screws (K).

Note: Two screws are required to mount each bracket to properly secure in place.



17. Apply Adhesive Tab (L) to flat, top surface of the Top Rail (A), near the post. Slide Bracket Covers (F) to interlock with flange on the Saddle Brackets (E).



18. Screw Mill Finish #10-1" Self-Drilling Screws (J) into the Top Rail (A) from the underside of Saddle Brackets (E) through the provided locating hole to securely fasten the rail in place.

