

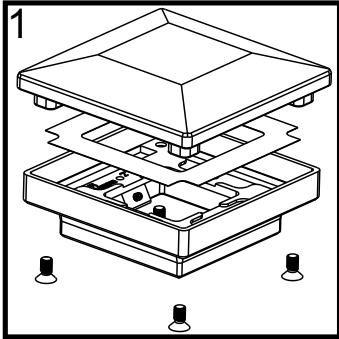

Installation Instructions 2" and 3" Flat Pyramid Caps Installed on Fe²⁶ or Al¹³ Posts

It is the responsibility of the installer to meet all code and safety requirements. The installer should determine and implement the appropriate installation techniques for each situation. The Fortress Company nor its distributors shall not be held liable for improper or unsafe installations.

Required Materials: Phillips Head Screw Driver, Eye Protection



1. The following components are included with the FortressAccents 2" and 3" Flat Pyramid Caps: Post Cap, Post Cap Base, Light Slot Cover, 4 - Machine Screws, 2 - Hex Head Set Screws, and a 2.5mm Hex Wrench.

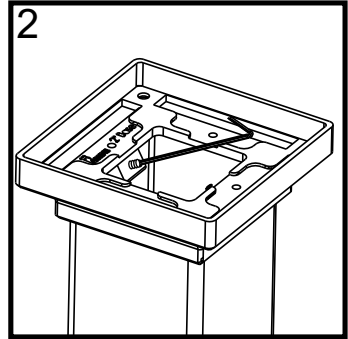

2. Place the Post Cap Base on the post. Using the supplied 2.5mm Allen Wrench tighten the two set screws. Adjust the screws to center and level the Post Cap on the post.

Remove the 4 Machine Screws, located at each corner. Remove the Post Cap and Light Slot Cover. **Do not discard the screws.** They will be used again.

If installing the optional FortressAccents LED Cap Light Kit, reference those instructions before installing FortressAccents Flat Pyramid Cap.

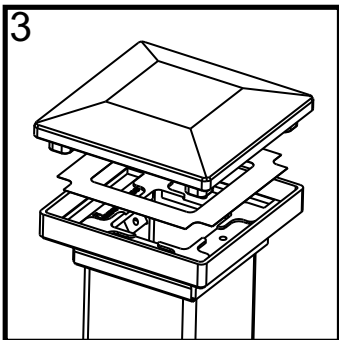

3. Place Light Slot Cover back onto Post Cap Base. Position Post Cap onto the Post Cap Base.

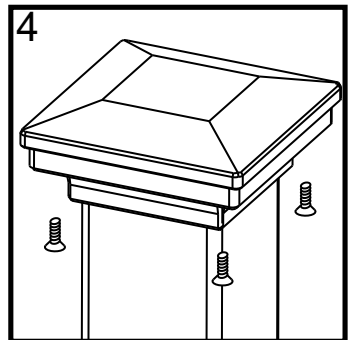

4. Secure Post Cap with the 4 Machine Screws that were removed in step 1.

Please visit www.fortressaccents.com for information on how to order additional accessories.

For technical assistance, please email: technicalhelp@fortressiron.com
Hours of Operation Monday through Friday 8:00 AM to 5:00 PM, CST
Phone: 1-866-323-4766(IRON) Fax: 972-644-3720
www.fortressaccents.com



Installation Instructions 3.5", 4" and 5" Flat Pyramid Caps Installed on Wood or Composite Posts

It is the responsibility of the installer to meet all code and safety requirements. The installer should determine and implement the appropriate installation techniques for each situation. The Fortress Company nor its distributors shall not be held liable for improper or unsafe installations.

Required Materials: Phillips Head Screw Driver, Drill, 1/8" Drill Bit, Eye Protection

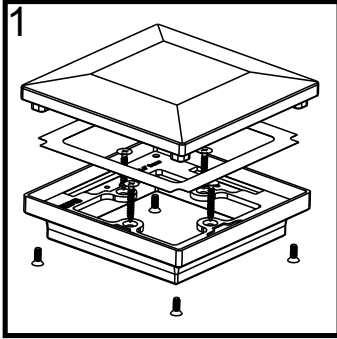

1. The following components are included with the FortressAccents 3.5", 4" and 5" Flat Pyramid Caps: Post Cap, Post Cap Base, Light Slot Cover, 4 - Machine Screws, and 4 - #10 X 3/4" Wood Screws. Note: 5" Flat Pyramid Caps include a Composite Adapter with 4 - Pan Head Machine Screws.

Remove the 4 Machine Screws, located at each corner. Remove the Post Cap and Light Slot Cover. **Do not discard the screws.** They will be used again.

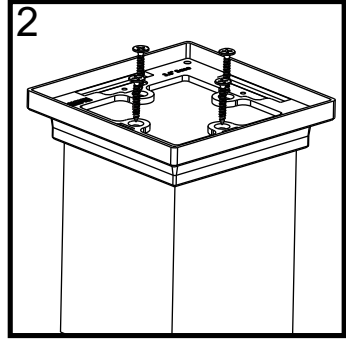

2. Place the Post Cap Base on the post and mark hole locations. Pre-drill holes with a 1/8" drill bit. Using the 4 supplied #10 X 3/4" Wood Screws, attach the Post Cap Base to post.

If the Flat Pyramid Cap is being installed on a vinyl post without a wood post insert, use a silicon adhesive to secure the Post Cap Base.

If installing the optional FortressAccents LED Cap Light Kit, reference those instructions before installing FortressAccents Flat Pyramid Cap.

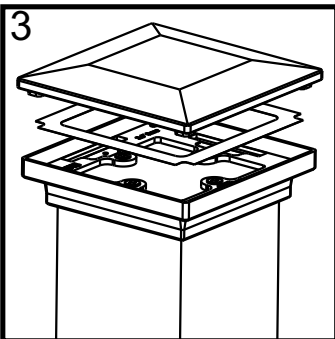

3. Place Light Slot Cover back onto Post Cap Base. Position Post Cap onto the Post Cap Base.

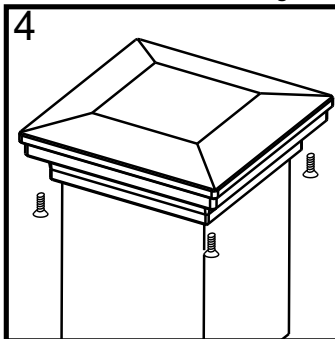

4. Secure Post Cap with the 4 Machine Screws that were removed in step 1.

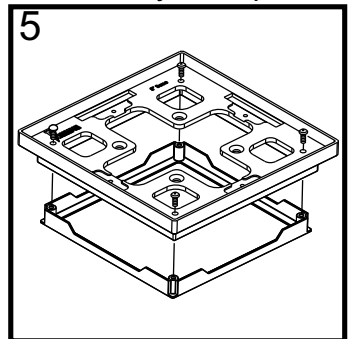

5. If installing FortressAccents 5" Flat Pyramid Post Caps on Composite Posts wider than 4.5" the Composite Adapter will need to be removed. With Composite Adapter removed the 5" Flat Pyramid Cap will fit posts up to 5" in width.

Please visit www.fortressaccents.com for information on how to order additional accessories.

For technical assistance, please email: technicalhelp@fortressiron.com
Hours of Operation Monday through Friday 8:00 AM to 5:00 PM, CST
Phone: 1-866-323-4766(IRON) Fax: 972-644-3720
www.fortressaccents.com