





Series 300 AFCO-Rail Level Rail



INSTALLATION INSTRUCTIONS

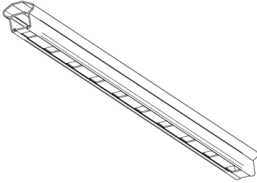
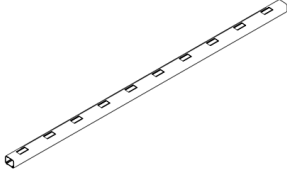
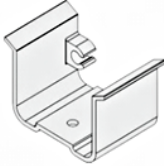
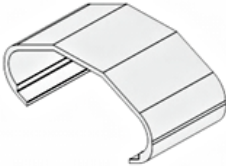

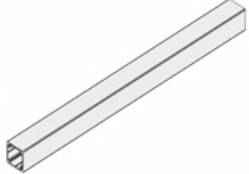
AFCO
Columns and Railings
a Division of AFCO Industries, Inc.

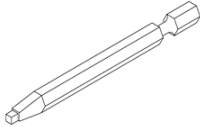
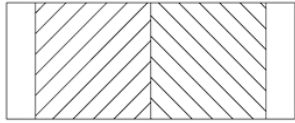
PARTS INCLUDED:			
TOP RAIL (1)		BOTTOM RAIL (1)	
A 		B 	
SADDLE BRACKET (2)	BRACKET COVER (2)	BOTTOM BRACKET (2)	10" SUPPORT BLOCK (1)
C 	D 	E 	F 
SUPPORT BLOCK CONNECTOR (2)	#10x1" SELF DRILLING SCREW (12)	3 1/2" SQUARE DRIVER BIT (1)	ADHESIVE TAB (1)
G 	H 	I 	J 

100 SERIES AFCO-RAIL LEVEL RAIL

TOOLS REQUIRED:

Drill bit 5/32" (.156")
 Drill (with adjustable clutch, recommended)
 Miter Saw (with metal cutting blade)
 Level
 Rubber mallet
 Tape measure
 Touch-up paint

NOTES:

- Posts and balusters packaged separately.
- An Optional AFCO-Tool is available to simplify the locating, pre-drilling and installation of brackets.

FOR A SUCCESSFUL INSTALLATION:

- Read the instructions completely before beginning the installation.
- Plan your railing project. Sketch your project with the actual measurements of your deck or balcony complete with post locations.
- Check local building codes to ensure compliance.
- Check carton(s) to determine part count is complete.
- After cutting rails, balusters, or posts, paint exposed metal for maximum protection against the elements.
- Installation is best accomplished with two people.
- Wear personal protection equipment; safety glasses, etc.
- Use care not to over-torque the screws. Pre-drilling is recommended.
- **Provided hardware to install AFCO-Rail is for use with Aluminum AFCO-Rail posts. If installing to other surfaces the installer must acquire the appropriate hardware as needed for proper installation.**

POSTS INSTALLATION:

1. Measure and locate the position of the post(s) based on the project layout.

2. Install the post by attaching the aluminum mounting flange to the surface of the deck or balcony. Position the post so the fastener will go into the floor joist, and make sure the decking is firmly attached to the joist at the location of the post. If necessary, use wood blocking as reinforcement underneath the decking where the posts are located. Post mounting fasteners should be able to secure into the joist or reinforcement braces, not just the decking itself. When installing AFCO-Rail Post on top of a wood surface, screws must be lagged into at least 3" of solid wood. Deck boards sized 5/4" or 1 1/2" do not provide sufficient material for a safe installation.

Note: When installing AFCO-Rail Post onto treated wood surface, install the provided ACO pad (included in the post kit) between the post base and the treated surface.

3. Position the post to the deck surface. Four 3/8" diameter mounting holes are provided on the mounting flange. Mark the mounting flange hole locations and remove the post. Drill the marked locations into the decking and reinforcement. Remount the post. Insert the appropriate fasteners to secure the mounting flange to the deck structure.

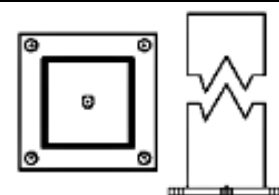

4. Finish by sliding the base trim to the bottom of the post to cover the mounting flange.

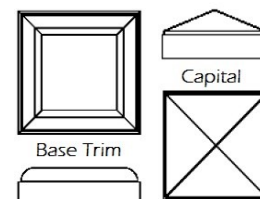

5. To install the post cap, set post capital in place on top of the post and tap lightly with a rubber mallet to drive the post cap onto the post. Silicone or water based caulking may be used to secure the post cap and base trim.

LEVEL RAIL INSTALLATION:

1. Carefully measure the opening between posts or walls and calculate the length of rail that needs to be cut. Divide the trim length amount in half, and starting with the Bottom Rail (B), transfer and mark the measurement to each end of the rail. For the sake of baluster spacing or personal preference, all of the trim length could be cut from one end of both rails. Make this determination before cutting the rails. Always refer to local building code requirements to determine the baluster spacing requirements in your area (4" maximum is typical). Carefully cut the rail. Mark Top Rail (A) and cut. For clearance purposes the top rail is pre-cut 3/4" shorter than the bottom rail.

2. Install Support Block Connectors (G) using #10x1" Self Drilling Screw (H) to the underside of Bottom Rail (B). The Support Block will be installed in step 11.
Note: One Support Block, cut from Support Block Material (F), is recommended for rails measuring 72" in length or less; two Support Blocks for longer lengths. If one Support Block is required, install the Support Block Connector (G) at center point of Bottom Rail (B). If two Support Blocks are required, install Support Block Connectors (G) equal distance from each end of the Bottom Rail (B).

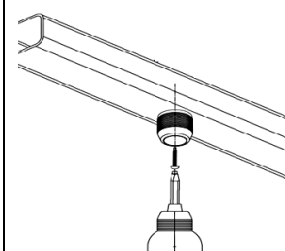

3. To assemble rail, begin with Top Rail (A) and insert balusters into each baluster hole. Use a rubber mallet to tap the balusters into place until fully seated into the Top Rail.

Note: It is recommended to use the box as a pad to prevent scuffing of the painted finish.

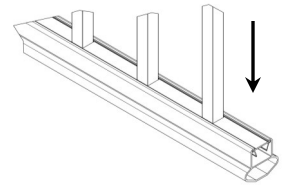

4. Insert balusters in the Bottom Rail (B) the same as in step 1, beginning at one end and working to the opposite end. Stand the assembly upside down on the surface of the box and tap the Bottom Rail (B) with a rubber mallet to secure the balusters in place. Stand assembly upright.

Note: Notches are provided on the front of the box to help align balusters and aid in the assembly of the rail in this step.

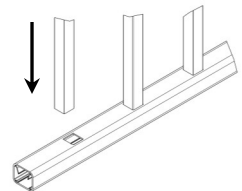

5. Slide Bottom Brackets (E) with screw holes down and counter bore holes facing toward the balusters, over each end of the Bottom Rail (B).

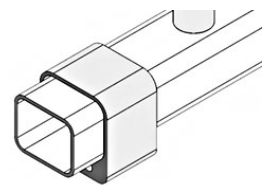

6. Slide Bracket Covers (D) at least 3-4 inches inward over each end of the Top Rail (A). A small piece of tape may be needed to hold the bracket covers in place.

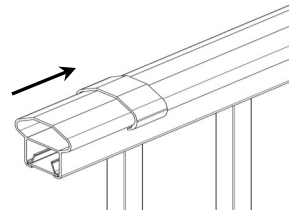

7. Measure up 34 1/2" (36" rail height) or 40 1/2" (42" rail height) from the floor and mark a level, horizontal line on the post or wall.

Note: This measurement may vary by local code or personal preference.

8. Align screw holes in Saddle Bracket (C) on the horizontal line making certain the Saddle Bracket (C) is centered on the post. Mark screw locations. Repeat process at opposite end.

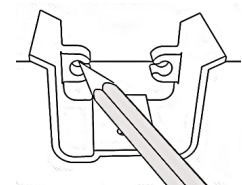

9. Attach both Saddle Brackets (C) with #10x1" Self Drilling Screws (H) at the marked screw locations completed in Step 8. Pre-drilling is recommended.

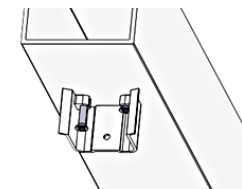

10. Set the rail assembly into the Saddle Brackets (C) letting the Bottom Rail (B) hang freely between the posts.

Note: Check for level.

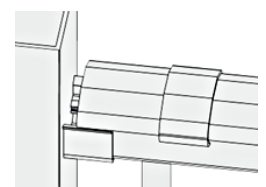

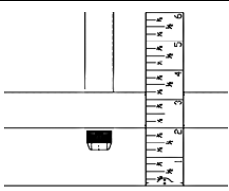
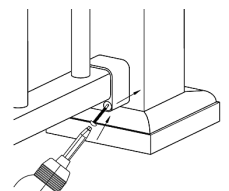
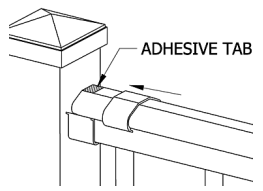
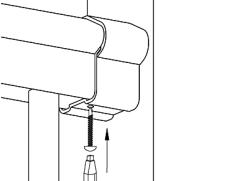
<p>11. At the point(s) where you installed Support Block Connector(s) (step 2), carefully measure the distance from the underside of the Bottom Rail (B) to the floor. Cut Support Block Material (F) to fit. Remove rail assembly from the Saddle Brackets (C). Slip Support Block(s) over Support Block Connectors (G). Slide the rail back into place and make certain the rail is plumb.</p>	
<p>12. Slide and hold the Bottom Bracket (E) firmly against the post or wall. Secure the bracket with #10x1" Self Drilling Screws (H). Repeat the process at the other side.</p> <p><i>Note: Screw holes in Bottom Bracket (E) are angled to make mounting the brackets easier.</i></p>	
<p>13. Apply Adhesive Tab (J) to flat, top surface of Top Rail (A), near the post. Slide Bracket Cover (D) to interlock with flange on the Saddle Bracket (C).</p>	
<p>14. #10x1" Self Drilling Screws (H) into the Top Rail (A) from the underside of each Saddle Bracket (C) through the provided locating hole to securely fasten the rail.</p>	

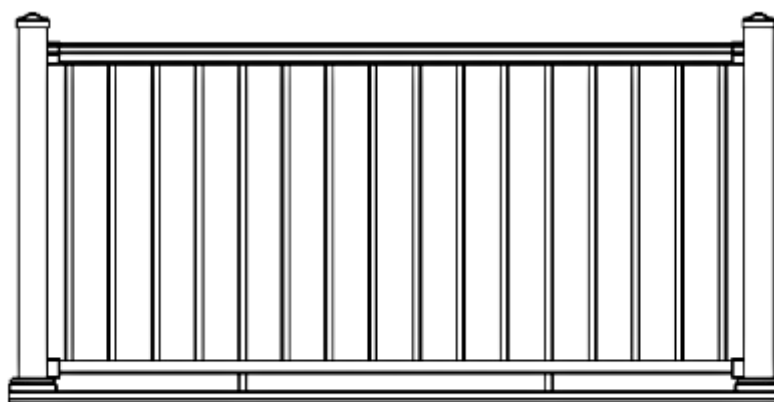

Installed View