

Installation Instructions, 3/4" OWT Thru-Bolt Timber Fasteners

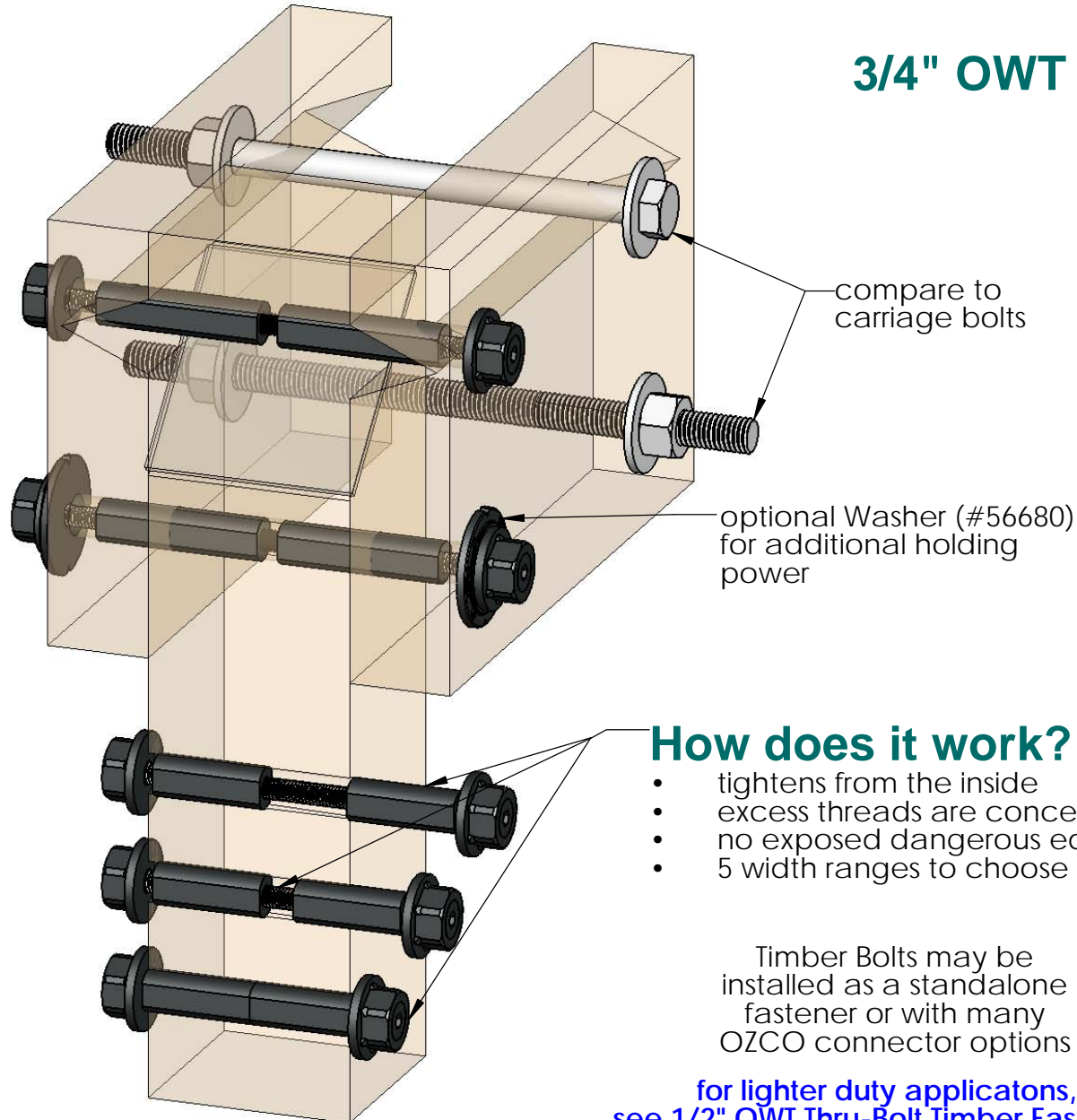

width range	Timber Bolt
1.5-4"	56673
4.25-6"	56649
6.25-8"	56650
8.25-10"	56651
10.25-12"	56652

- Timber Bolts are usable .25" past documented range, however use table for best selection
- Timber Bolts can accommodate 2 #56680 washers in MAX range
- Recommended MAX tightening torque: 10in/lbs
- Width range tolerance: +.25"/-.0
- Timber Bolts with 2 connectors: custom widths are possible when eliminating 1 connector & stud

How does it work?

- tightens from the inside
- excess threads are concealed
- no exposed dangerous edges
- 5 width ranges to choose from

Timber Bolts may be installed as a standalone fastener or with many OZCO connector options

for lighter duty applications,
see 1/2" OWT Thru-Bolt Timber Fasteners

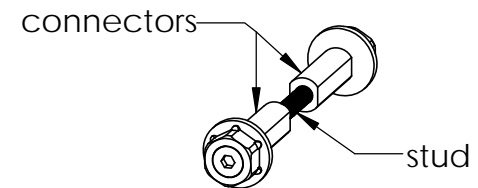

OWT Ornamental
Wood Ties

OZCO BUILDING PRODUCTS

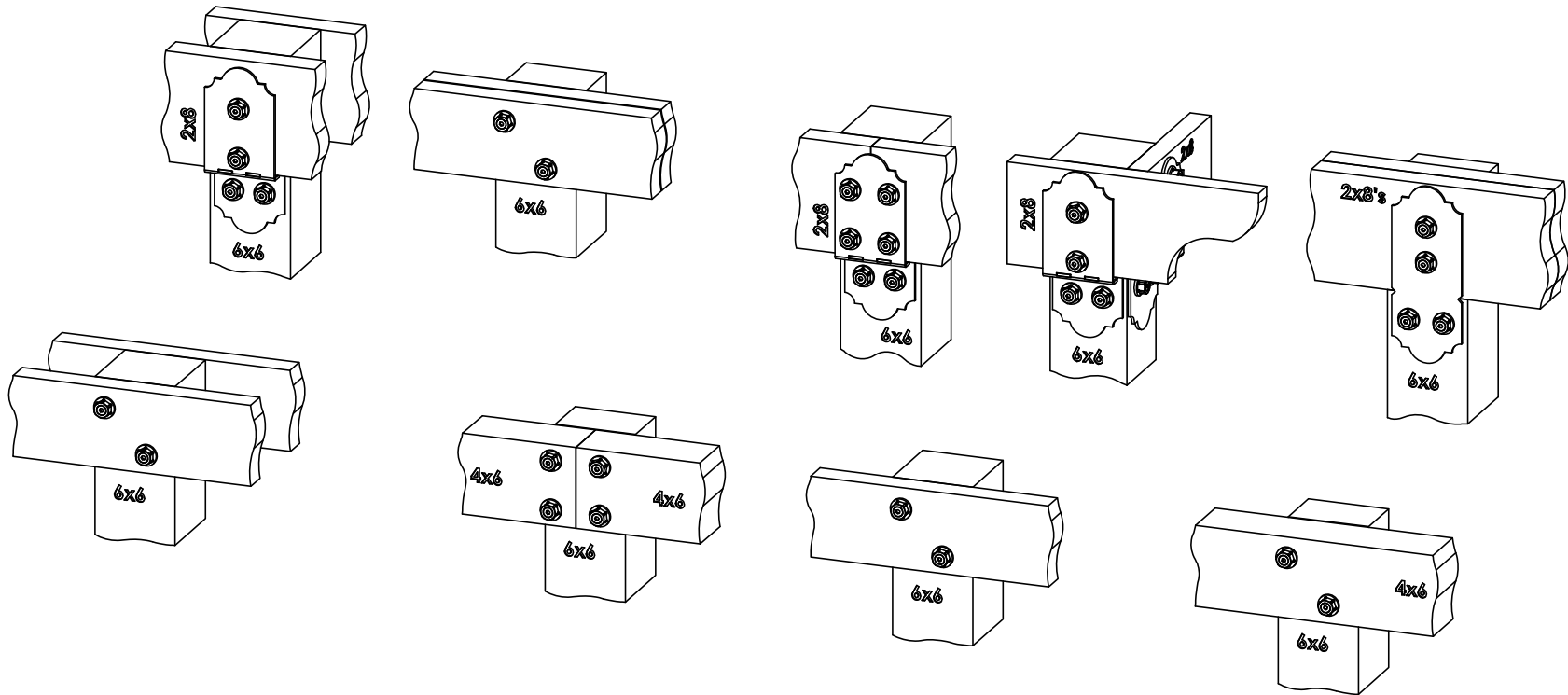

Applications

Installation Instructions, .75 OWT Thru-Bolt
Timber Fasteners

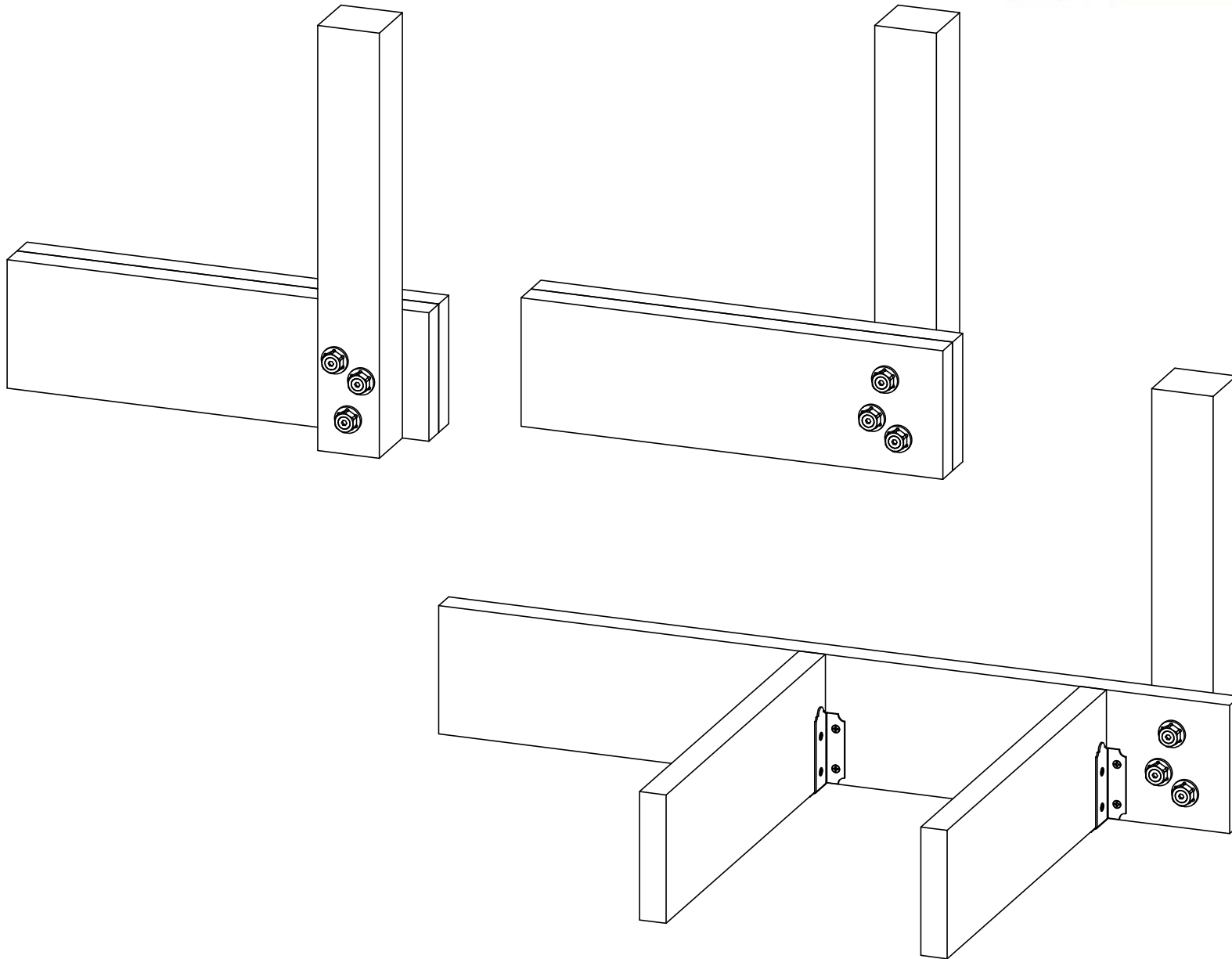

Applications

Installation Instructions, .75 OWT Thru-Bolt
Timber Fasteners

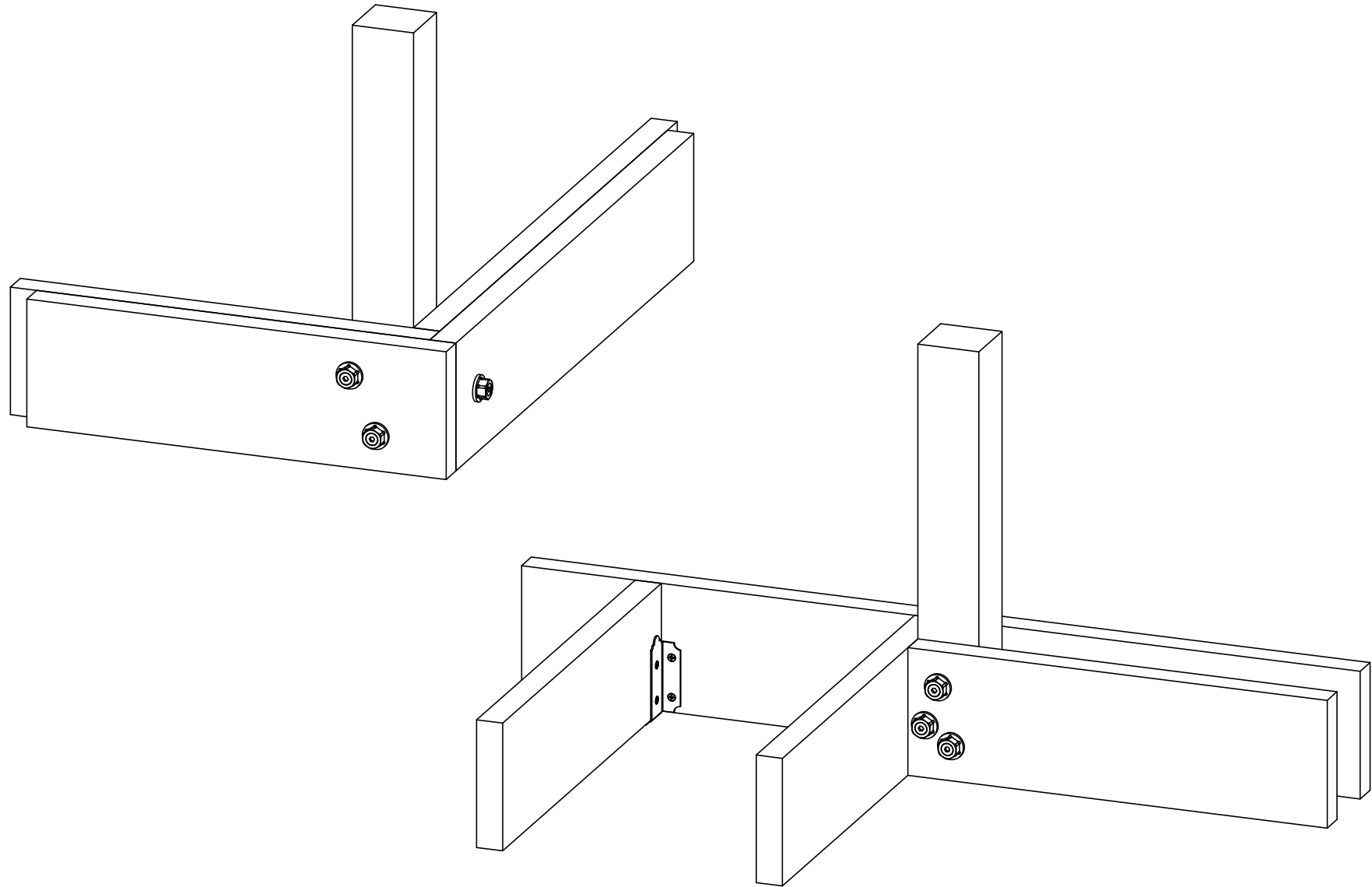

Applications

Installation Instructions, .75 OWT Thru-Bolt
Timber Fasteners

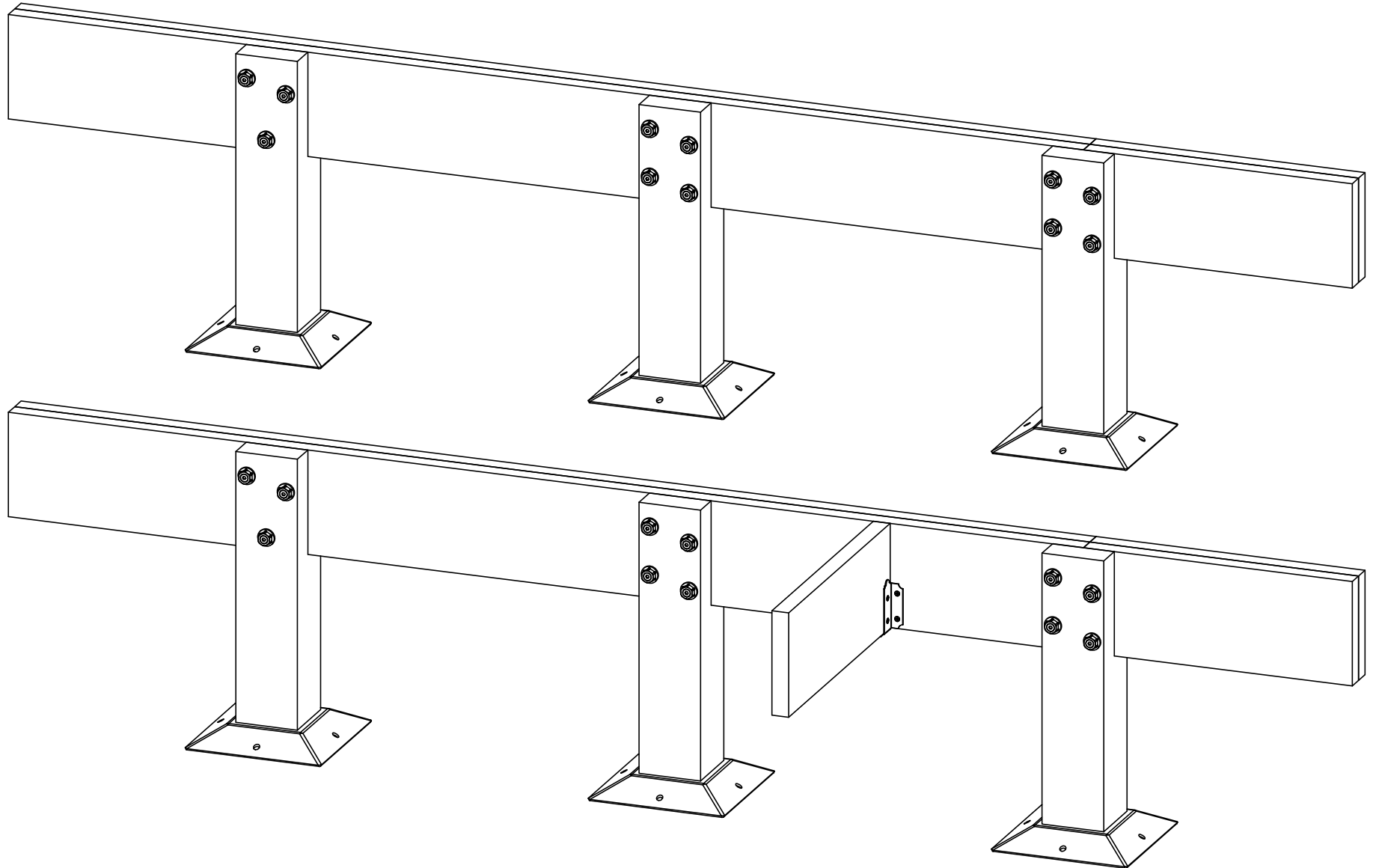

Applications

Installation Instructions, .75 OWT Thru-Bolt
Timber Fasteners

V2.00 - Installation Instructions, Specifications and Project Plans are effective 4/21/2016 . This information is updated periodically and should not be relied upon after 2 years from 4/21/2016 . Please visit OZCOBP.com to get current information.

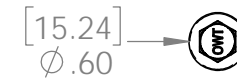
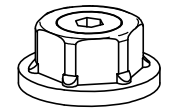
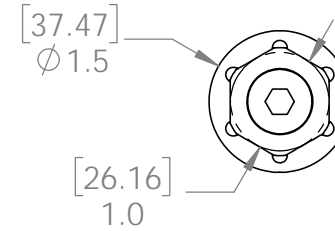
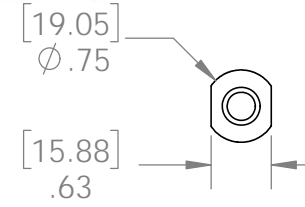
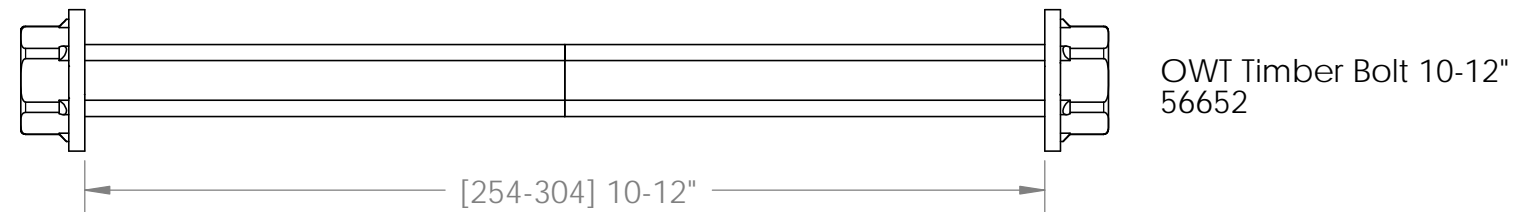
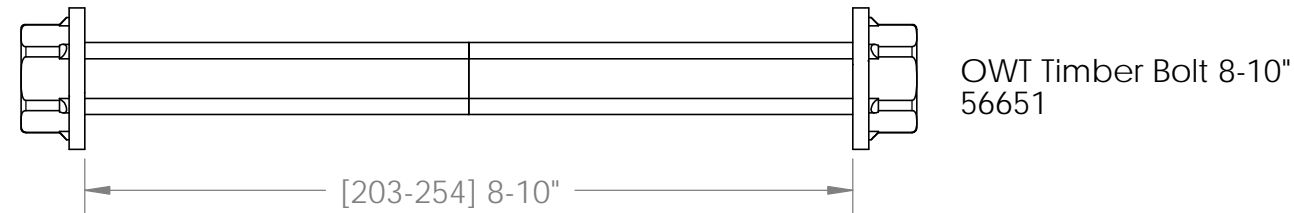
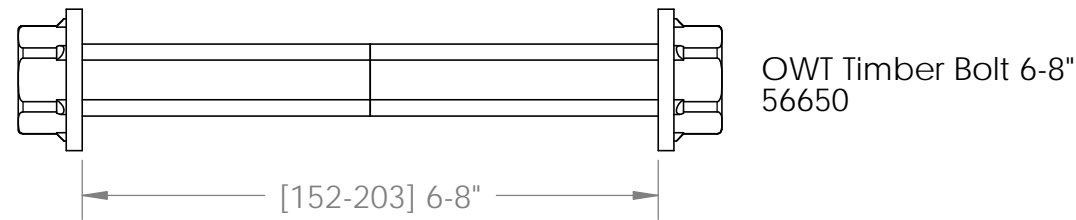
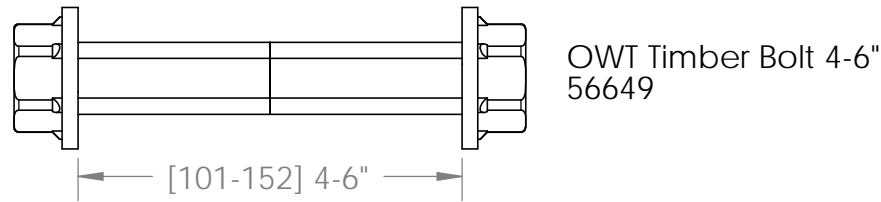
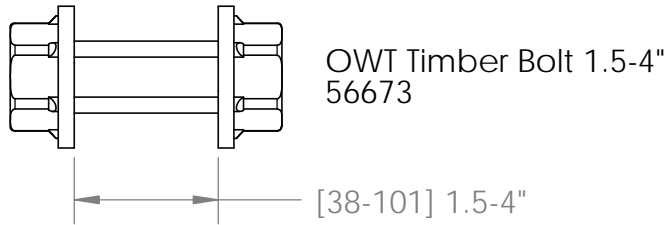

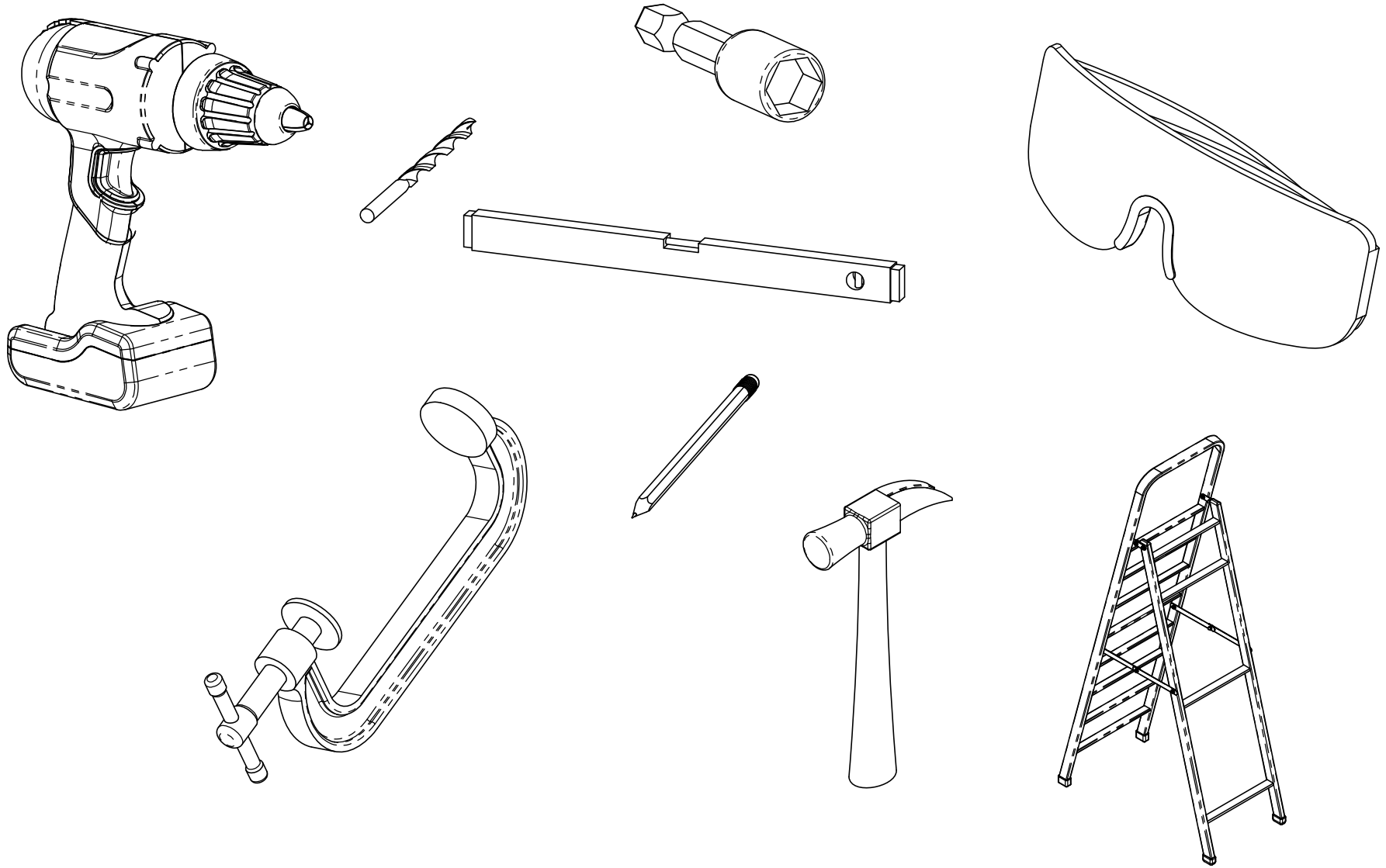

Suggested Tools

(others may be required)

Installation Instructions, .75 OWT Thru-Bolt
Timber Fasteners

Installation

1. Drill $\varnothing 3/4"$ thru hole
2. Remove HCN cap, HCN & Timber Bolt Screw
3. Adjust width of Timber Bolt by turning connectors
4. Insert into thru hole
5. Reinstall cap, HCN & Timber Bolt Screw

current and subsequent pages will illustrate these steps

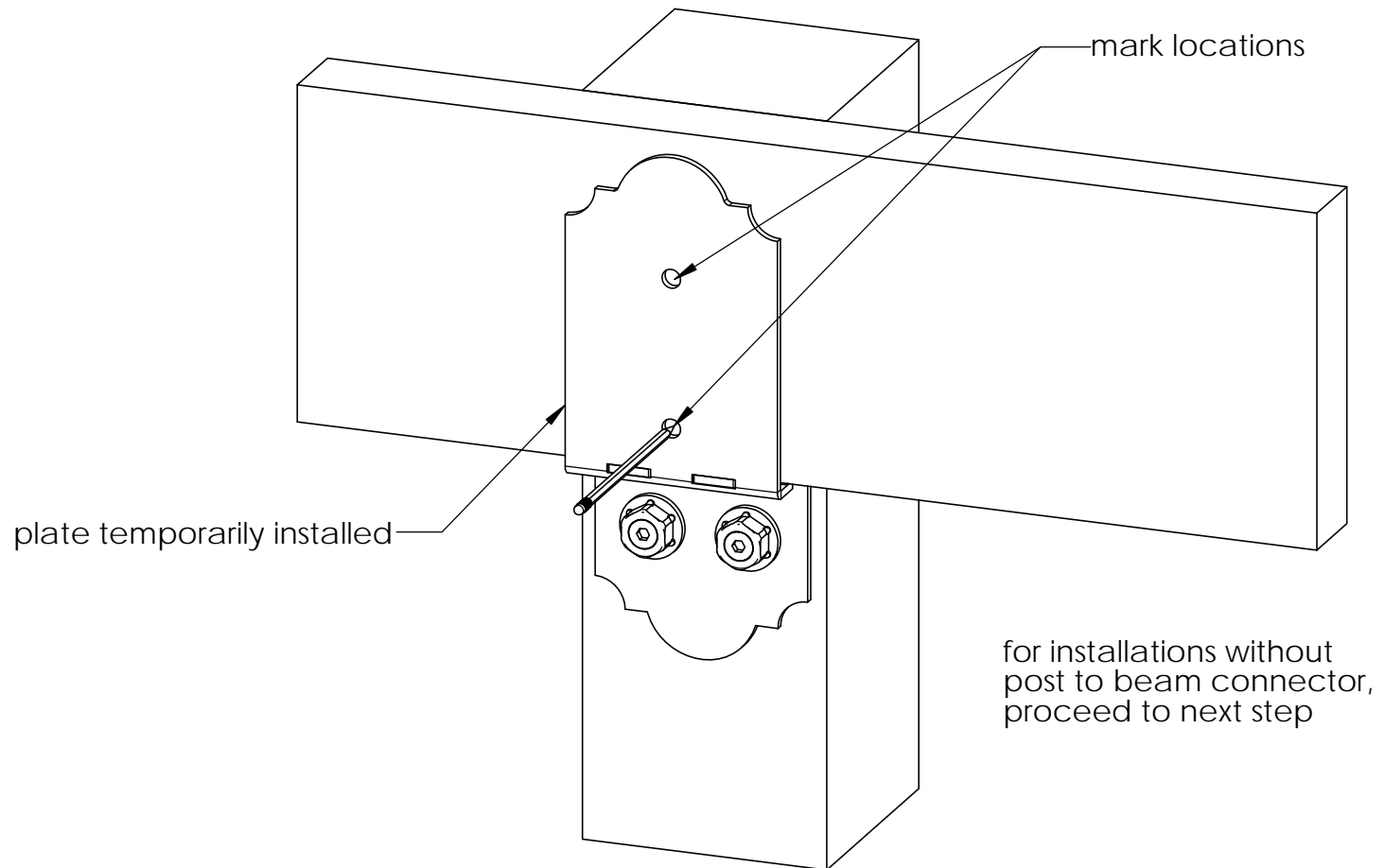

step 1

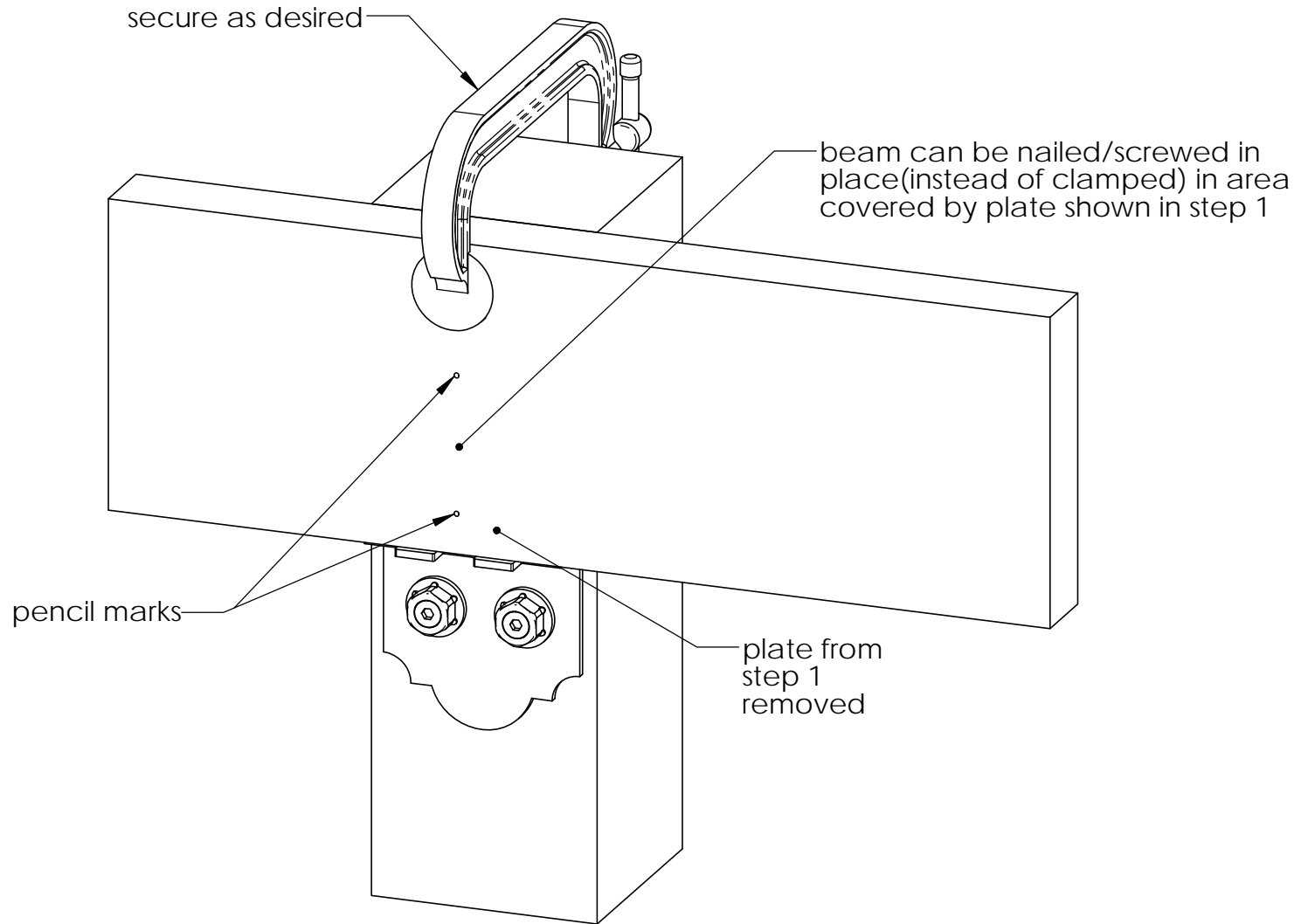

step 2

Installation Instructions, .75 OWT Thru-Bolt
Timber Fasteners

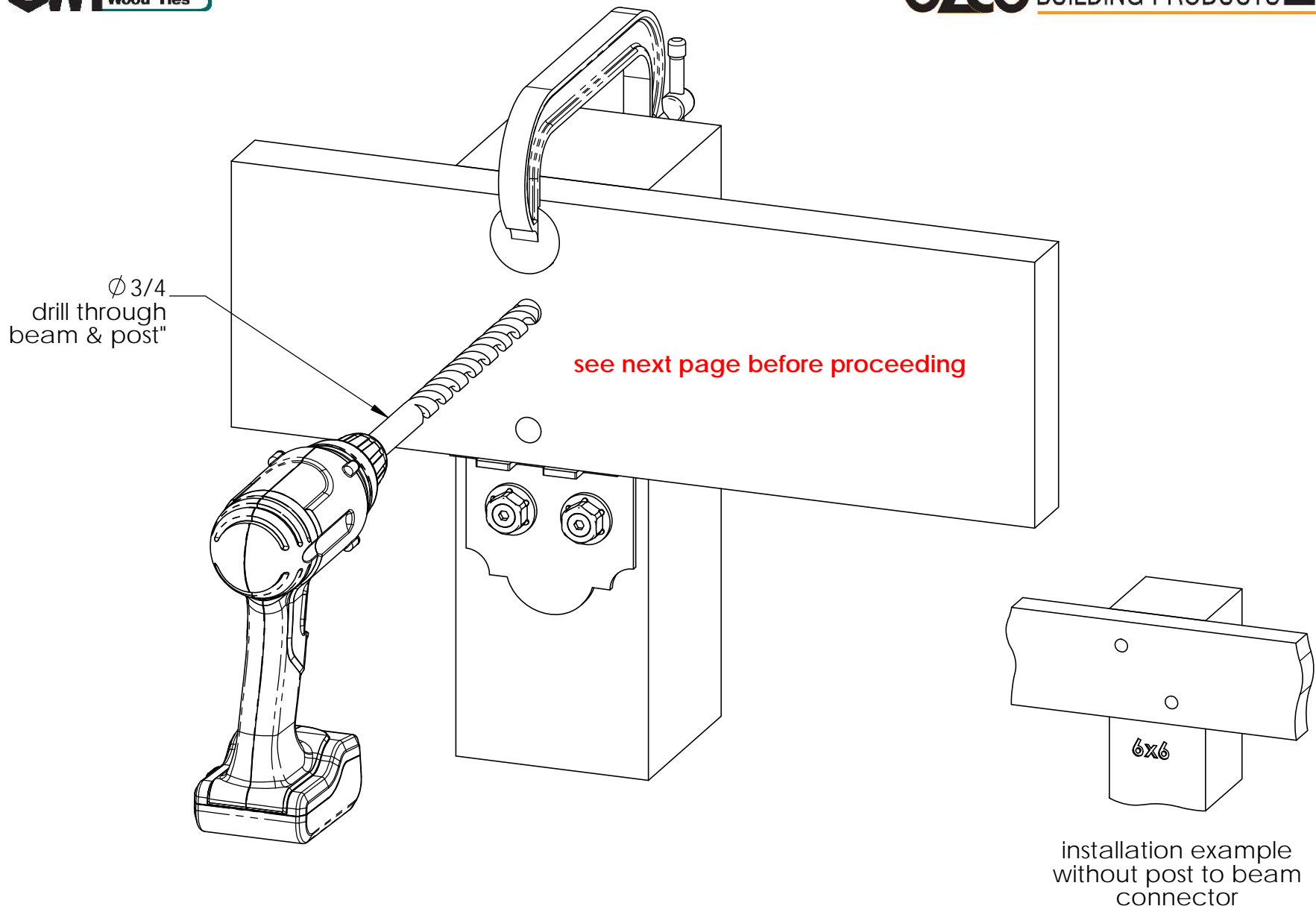

step 3

Installation Instructions, .75 OWT Thru-Bolt
Timber Fasteners

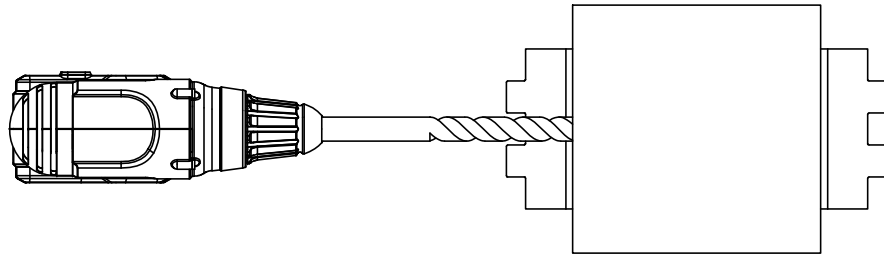

2 Beam Installation shown
 Drill holes as level as possible to ensure straight path to align with hole from opposite side

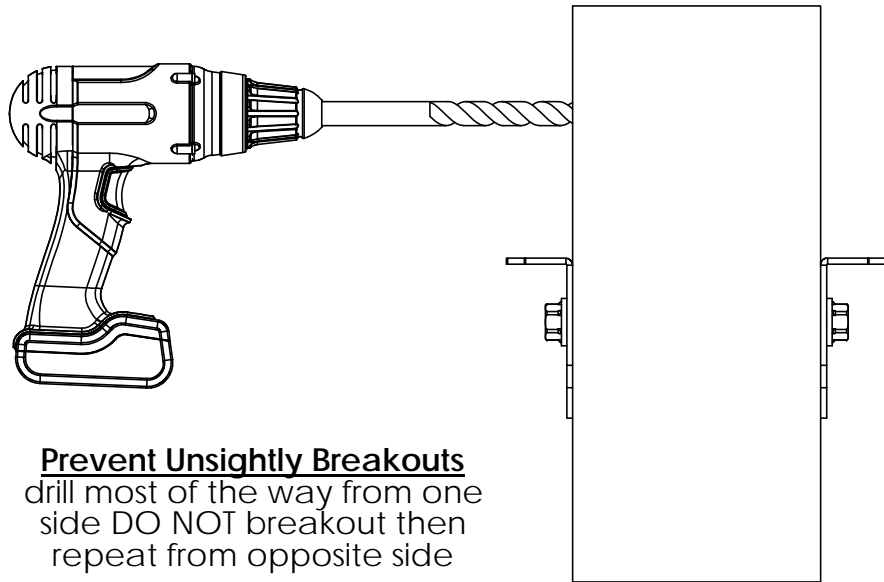

Prevent Unsightly Breakouts
 drill most of the way from one side DO NOT breakout then repeat from opposite side

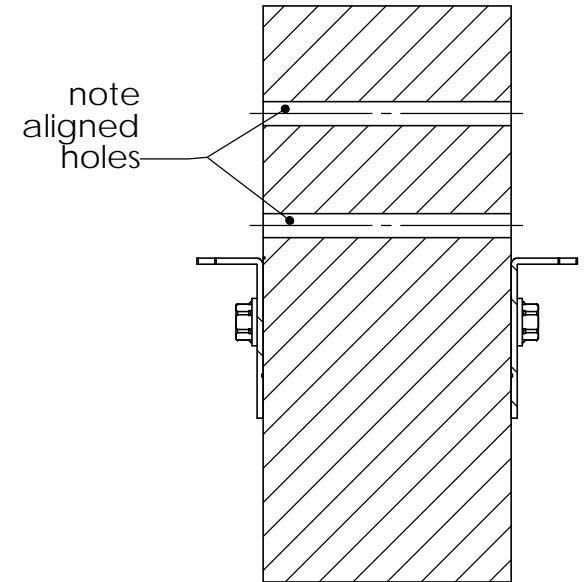
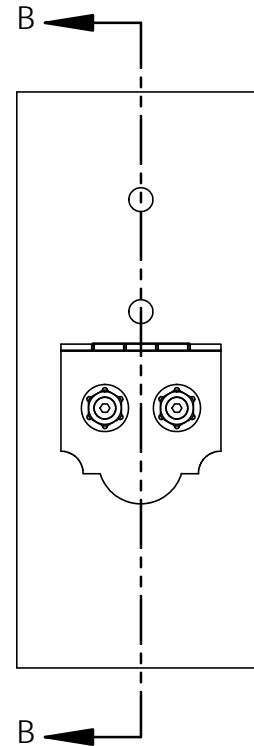

SECTION B-B
 SCALE 1 : 6

step 3 supplement

Installation Instructions, .75 OWT Thru-Bolt Timber Fasteners

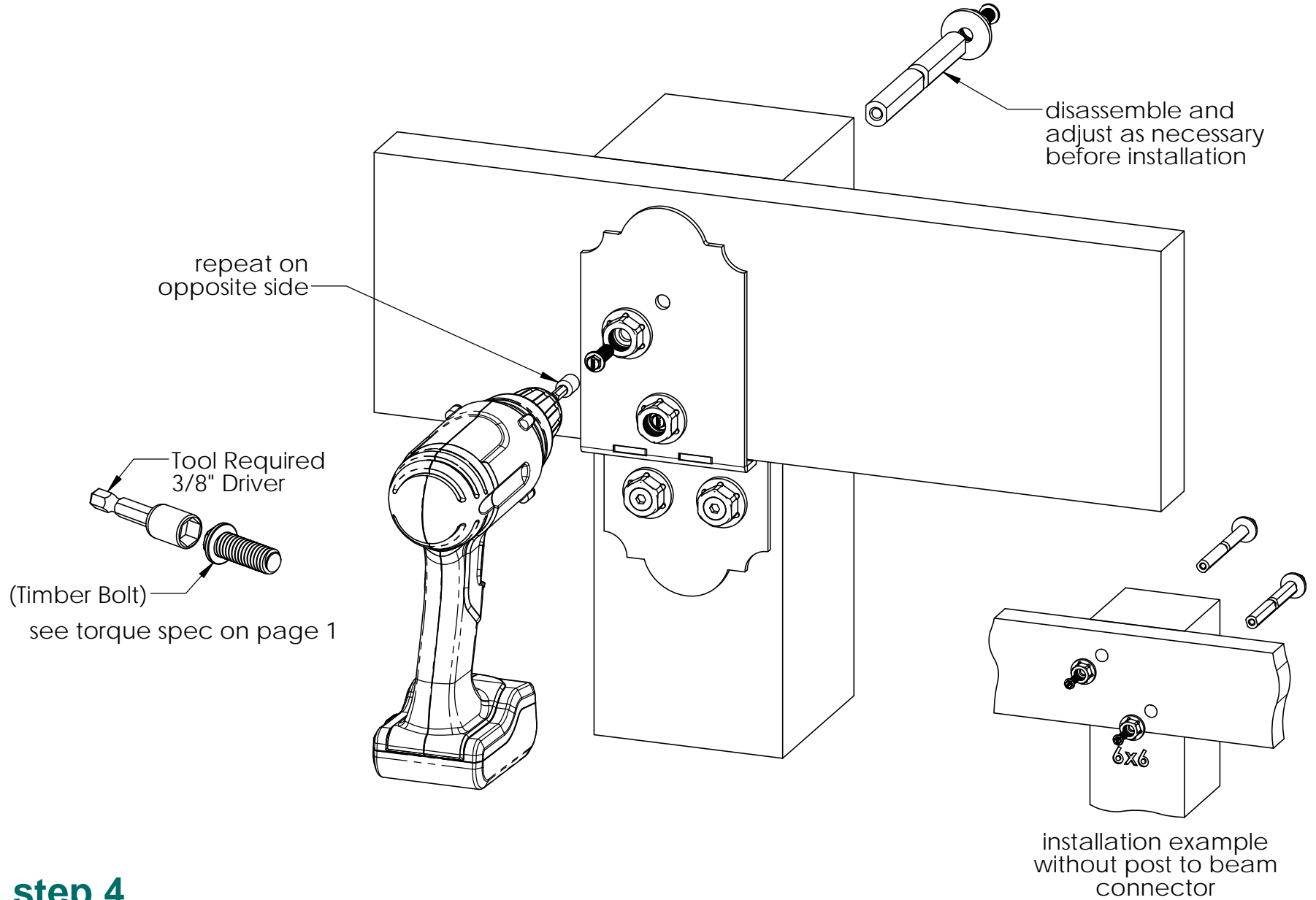

step 4

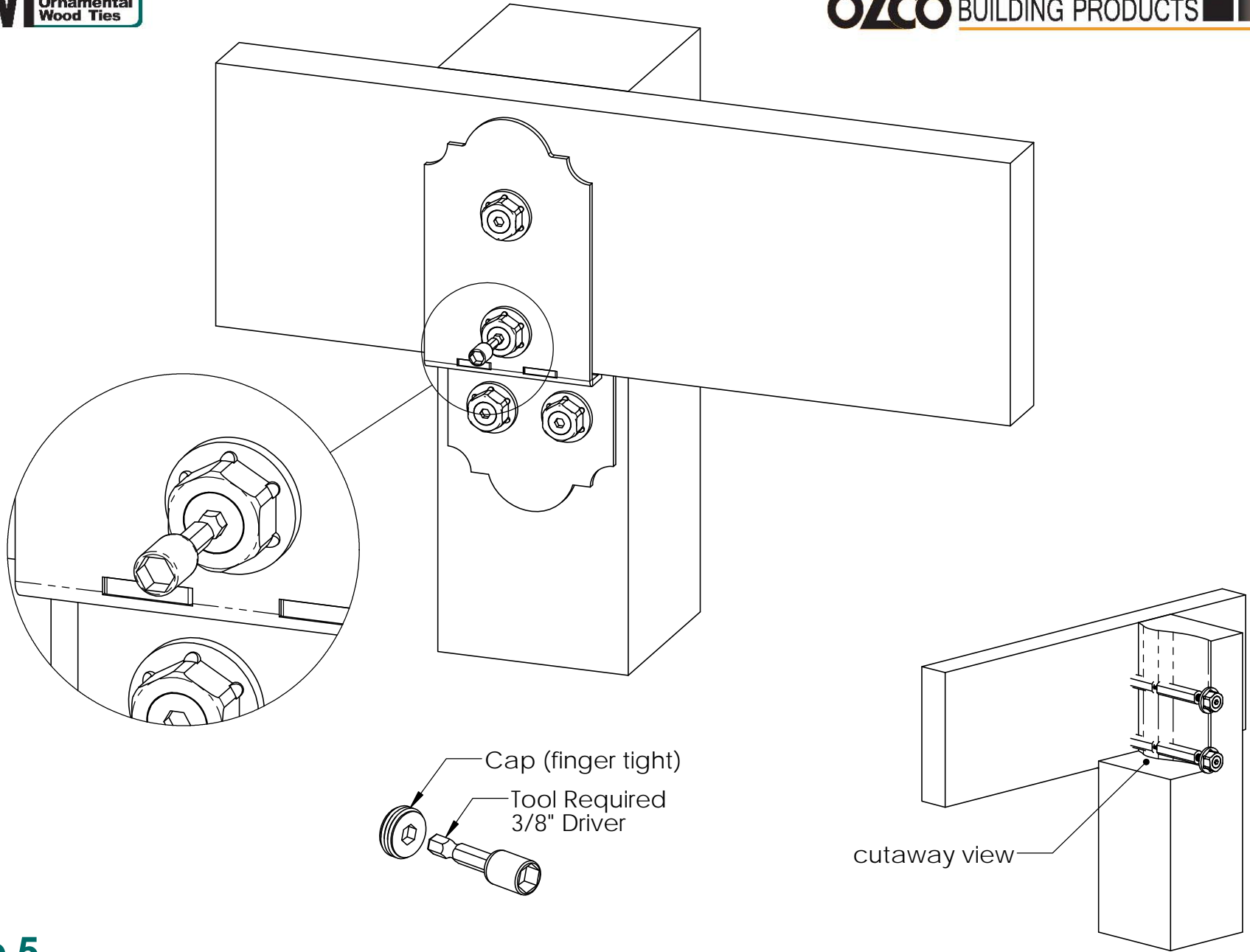

step 5

Installation Instructions, .75 OWT Thru-Bolt
Timber Fasteners