



RAILING & DECKLITES®

INSTALLATION & MAINTENANCE GUIDE

| DECKING
RAILING

| LIGHTING
ACCESSORIES

| www.timbertech.com

MAY 2012

Contents

General Information

Introduction.....	2
Code Listings.....	2
Railing Product Choices.....	3

Installation Guidelines

Railing Systems

RadianceRail® System

Product Overview.....	4
Straight & Angled Rails.....	5-6
Stair Rails.....	7-9

RadianceRail® Express System

Product Overview.....	10
Straight & Angled Rails.....	11-12
Stair Rails.....	13

Ornamental Rail System

Product Overview.....	14
Straight & Angled Rails.....	15
Stair Rails.....	16-17

BuilderRail® System

Product Overview.....	18
Straight & Angled Rails.....	19-20
Stair Rails.....	21-23
Cap Rail Details.....	24

Care & Cleaning

Storage.....	25
Ice & Snow Removal.....	25
Removing Mildew & Stains.....	25
RadianceRail Touch-Up.....	25

ADA Compliant Hand Rail System

Component & Installation.....	26-27
-------------------------------	-------

Secure - Mount Post System

Component & Applications.....	28
Composite & Concrete Installation.....	29

DeckLites®

General Information

Components.....	30
Tools Required.....	30
Safety Precautions.....	30

Installation Guidelines

Layout Overview.....	31
Wiring Instructions.....	32-33
Component Installation.....	34-37

Warranty

Warranty Information.....	38-40
Warranty Card.....	41

Do you need help with your installation?

TimberTech strives to provide the very best services to our customers. We have an excellent customer service team that is here to help you with your installation questions. If you need help you can call customer service at 1-800-307-7780 or visit www.timbertech.com/installation to view TimberTech installation videos.

Dear Valued Customer:



TimberTech would like to thank you for your interest in our railing systems. We strive to better serve our customers and hope that you have a wonderful experience with TimberTech.

TimberTech focuses on quality, innovation and brand in all that we do. With an assortment of plank profiles, industry leading railing systems, fencing and numerous accessories, building beautiful decks has never been easier.

TimberTech is committed to providing builders and professional deck installers with exciting new products our customers demand, as well as programs and support material to differentiate themselves in the marketplace.

TimberTech is a member of the Crane Building Products family of companies, which is part of the Crane Group, a more than 60-year old family owned company.

TimberTech has compiled this Railing & DeckLites® Installation & Maintenance Guide to provide a thorough resource for technical information for our railing systems and deck lighting system.

To get information on other TimberTech products visit timbertech.com or ask your dealer for these installation guides:

- **TimberTech Decking & DrySpace™ Installation & Maintenance Guide**
- **TimberTech FenceScape® Installation & Maintenance Guide**

Installing TimberTech

TimberTech offers four innovative railing systems. A variety of color choices allow you to match or complement your TimberTech deck planks.



RadianceRail®

A clean, crisp look with no exposed hardware



RadianceRail® Express

High-quality capped wood composite railing at a best-in-class value.



Ornamental Rail

The look and feel of real wood

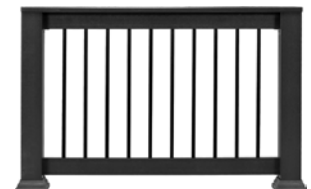

BuilderRail®

Black metal balusters with TimberTech BuilderBoard rails

TimberTech products are a revolutionary alternative to traditional wood—they don't rot, warp or splinter—and they look great year after year. And unlike wood, TimberTech products require no painting, staining or sealing.

Make sure your project meets local building codes before you begin installation.

These installation guidelines will direct you through the process of installing TimberTech railing systems. These methods are recommended by TimberTech but may not cover every installation scenario you encounter. Since each installation is unique in its performance requirements, the ultimate installation method used is the sole responsibility of the installer. TimberTech recommends that all designs be reviewed by a licensed architect, engineer or local building official before installation.

TimberTech Code Listings

Once a product is tested by an independent lab, an application and report is submitted to one of several agencies that provide listings for building products that meet the requirements of Acceptance Criteria 174 (AC 174) as set forth by the International Code Council Evaluation Service (ICC-ES). TimberTech currently has listings from the ICC-ES and Architectural Testing Inc. The following TimberTech reports on code compliance are available to download on www.timbertech.com.

For the most up-to-date code listings visit www.timbertech.com/installation.

ICC Evaluation Service, Inc.

ICC ESR-1400 • Ornamental Rail System



Underwriters Laboratories, Inc.

E319591 • DeckLites

ATI Architectural Testing, Inc.

CCRR-0114 • RadianceRail

CCRR-0129 • BuilderRail

Code listing for RadianceRail Express Pending

Test Reports:

ADA Hand Rail & Secure Mount Post System tested to requirements of ICC-ES-AC-174

Railing Product Choices

RAILING & RAILING ACCESSORIES	Size										
		Cedar	Grey	Redwood	Antique White	Classic Black	Coastal White	Mountain Cedar	RiverRock	SandRidge	Traditional Walnut
RADIANCE RAIL®											
6' RadianceRail Complete Kit-Square Balusters	6' length - 36" high					X	X				
8' RadianceRail Complete Kit-Square Balusters	8' length - 36" high					X	X				
6' RadianceRail Rail Pack	6' length				X	X	X	X	X	X	X
8' RadianceRail Rail Pack	8' length				X	X	X	X	X	X	X
8' RadianceRail Custom Rail Pack (no pre-drilled holes)	8' length				X	X	X	X	X	X	X
6' Baluster Pack - Square Balusters	6' length, 36" high / 42" high				X	X	X	X	X	X	X
8' Baluster Pack - Square Balusters	8' length, 36" high / 42" high				X	X	X	X	X	X	X
Hardware Mounting Kit	N/A										
Post Cover for 4x4 Post (use with 36" rails)	5" x 5" x 42"				X	X	X	X	X	X	X
Post Cover for 4x4 Post (use with 42" rails)	5" x 5" x 12'				X	X	X	X	X	X	X
Post Cap and Post Skirt	N/A				X	X	X	X	X	X	X
RADIANCE RAIL® EXPRESS											
6' RadianceRail Express Rail Pack	6' length					X	X				X
8' RadianceRail Express Rail Pack	8' length					X	X				X
8' RadianceRail Express Stair Rail Pack	8' length					X	X				X
6' Baluster Pack - Square Balusters	6' length, 36" high / 42" high					X	X				X
8' Baluster Pack - Square Balusters	8' length, 36" high / 42" high					X	X				X
Post cover for 4x4 Post (use with 36" rails)	4"x4"x 39"					X	X				X
Post cover for 4x4 Post (use with 42" rails)	4"x4"x 8'					X	X				X
Hardware Mounting Kit	N/A					X	X				X
Hardware Mounting Kit for stairs	N/A					X	X				X
Gasket Pack	N/A					X	X				X
Post Cap and Post Skirt	N/A					X	X				X
ORNAMENTAL RAIL											
6' Ornamental Rail Kit:	6' length	X	X	X							
8' Ornamental Rail Kit:	8' length	X	X	X							
6' Baluster Kit, 16 Pre-Cut Solid Square, 36" rail ht.	1.3" x 1.3" x 27"	X	X	X							
8' Baluster Kit, 20 Pre-Cut Solid Square, 36" rail ht.	1.3" x 1.3" x 27"	X	X	X							
4' Post Cover for 4x4 Post	4.25" x 4.25" x 4'	X	X	X							
12' Post Cover for 4x4 Post	4.25" x 4.25" x 12'	X	X	X							
Baluster, Solid Square	1.3" x 1.3" x 12'	X	X	X							
Post Cap and Post Skirt	N/A	X	X	X							
BUILDER RAIL®*											
6' BuilderRail Kit: Black Classic Metal Balusters	6' length, 36" high / 42" high										
8' BuilderRail Kit: Black Classic Metal Balusters	8' length, 36" high / 42" high										
8' BuilderRail Stair Kit: Black Classic Metal Balusters	8' length, 36" high / 42" high										
BuilderRail Post Brackets - Black	90°										
BuilderRail Stair Post Brackets - Black	125°										
BuilderBoard® Rails	6' or 8' lengths	X	X	X							
Post Skirt	N/A	X	X	X							
Foot Blocks		X	X	X							
* Use Ornamental Rail Post Covers and Post Skirts with BuilderRail.											
ADA HAND RAIL SYSTEM											
Grab Rail with Aluminum Insert	1.5"OD x 104"					X	X				
Aluminum Joiner Kit	1"OD x 6"										
Inside/Outside Corner	1-1/2"OD x 4"x 4"					X	X				
Inline Wall Mount Bracket	3"					X	X				
Inside Corner 90° Standoff Bracket	6-1/4"					X	X				
End Cap	1-1/2"					X	X				
Handicap Loop	18" x 12" x 18"					X	X				
Adjustable Internal Joiner											
90° Return Bracket	3.75" x 3.5"					X	X				
External Swivel Connector						X	X				
Standoff Bracket	2-1/4"					X	X				
SECURE-MOUNT POST SYSTEM											
Secure-Mount Post	36" - Adjusts to 42" high if needed										
Deck Mounting Kit (includes leveling kit)	N/A										

RadianceRail® System

Visit www.timbertech.com/installation to view TimberTech installation videos.

- Consult your local building codes for guard and handrail requirements.

RadianceRail kits are available in 6' or 8' lengths.

Measure Your Railing Area

- Measurements are from center to center of post. Kits are produced to 6' and 8' to allow for finished end cuts and angles.
- Determine how many 6' or 8' RadianceRail Kits you need and check to be sure you have all the components (and quantities) listed in the chart and shown to the right.

Important Information

- RadianceRail 6' and 8' Kits are designed not to exceed 6' and 8' center of post to center of post, respectively.
- For stair applications maximum rail length must not exceed 91".
- 4x4 lumber posts or TimberTech post mount system should be installed plumb.
- Cut slowly, using a fine tooth saw blade to avoid chipping.

Component Dimensions

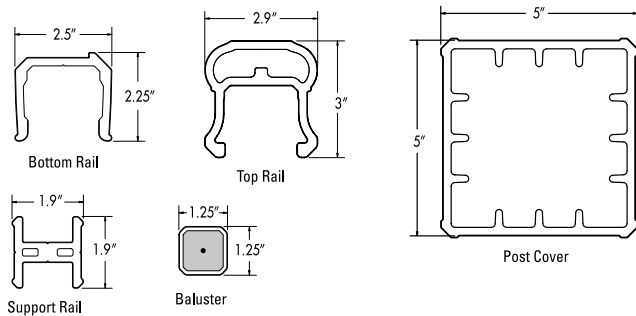

Tools Required

- Miter Saw
- 7/64" and 3/16" drill bits
- Drill
- Tape Measure

Components Needed For Installing One RadianceRail System	
Components Included in Complete 6' and 8' Kits (Classic Black and Coastal White Only)	1 - Top Rail 1 - Bottom Rail 2 - Support Rails Foot Blocks - 1 in 6' Kits - 2 in 8' Kits Square Balusters -13 in 6' Kits -18 in 8' Kits Hardware Mounting Kit Support Block Mounting Templates Baluster Screw Kit T-20 Torx driver bit
Components available separately for mix-and-match rail systems	RadianceRail Rail Pack 1 - Top Rail 1 - Bottom Rail 2 - Support Rails Hardware Mounting Kit Support Block Mounting Templates Foot Blocks - 1 in 6' Kits - 2 in 8' Kits T-20 Torx driver bit
Baluster Pack	Square Balusters -13 in 6' kits - 18 in 8' kits -36" kit - 28-1/2" height -42" kit - 34-1/2" height Baluster Screw Kit-6' Kits 13 - #8x2" Coated Screws 13 - #8x3" Coated Screws Baluster Screw Kit-8' Kits 18 - #8x2" Coated Screws 18 - #8x3" Coated Screws
Hardware included in Hardware Kits:	Hardware Mounting Kit 4 - Mounting Brackets 4 - Support Blocks* 12 - #8x3/4" Screws 6 - #8x2" Screws 16 - #8x3" Green Coated Screws
	*Support Block Only two support blocks are required for straight and angled sections. Four are required for each stair rail.
Additional Components Needed for Each System	2 - Post Covers 2 - Post Caps 2 - Post Skirts

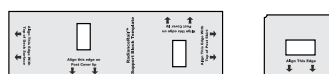
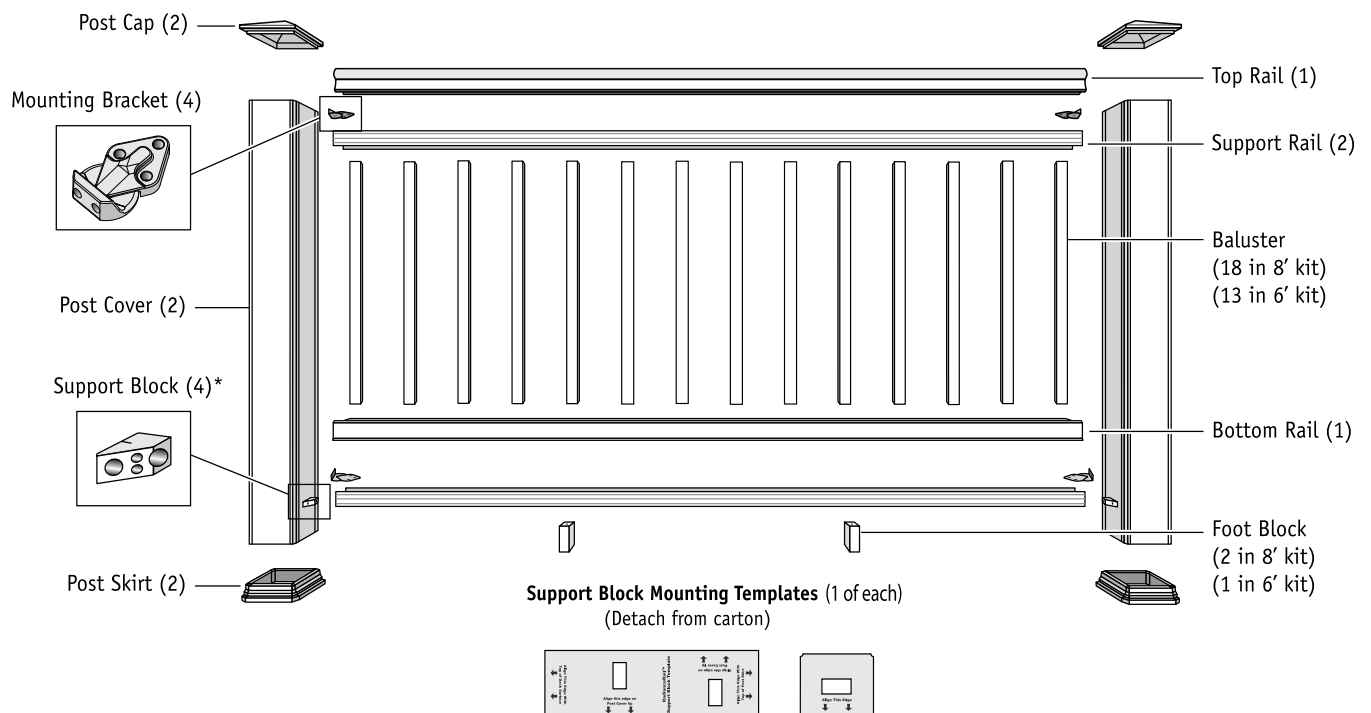

Installing Straight and Angled Rails - RadianceRail

1 Install Post Covers

- Trim Post Covers to desired length. 38-1/2" above deck surface is optimal for 36" railing heights, but could be longer if desired. If installing DeckLites, refer to DeckLites LED Instructions.
- Slide Post Cover and Post Skirt over post. Cover should slide easily over post, DO NOT FORCE.
- Using a level and shims, plumb the post cover vertically. Taking the time to do this will make the installation process much easier.

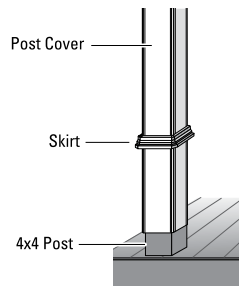

2 Install Lower Support Blocks

- Locate and detach the Support Block Mounting Template from the hardware compartment of the carton.
- Position template at the bottom of the Post Cover, resting it on the top of the Post Skirt. (Note: The template can be used with or without a Post Skirt. Follow the instructions on the template for your application.)
- Use template to align Support Block to center of post, pre-drill with 7/64" drill bit and attach with two #8 x 3" green coated screws.
- If you do not have the template, position the top of the support block 4" above the deck surface or 2-1/2" above the top of the post skirt centered left to right.

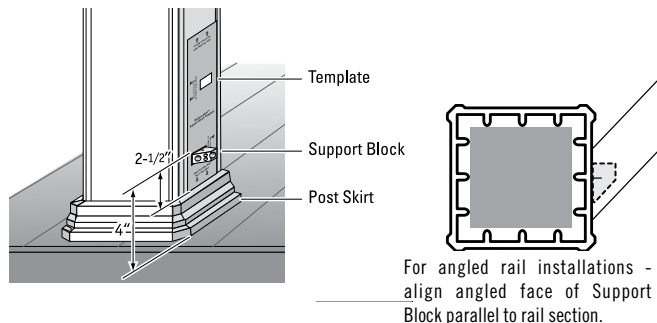

3 Cut and Pre-Assemble Bottom Support Rail

- Measure the distance between the posts near the bottom and the angle if needed, to the rail run.
- Cut the bottom Support Rail to length. For ease of installation, the pre-drilled holes in the Support Rail should not be within 2-1/4" of your end cuts.
- Position Mounting Brackets at each end of the Support Rail, pre drill with 7/64" drill bit and attach with #8 x 3/4" coated screws.
 - For straight sections:** align bracket face to rail end, and align center screw to rail centerline.
 - For angled sections:** align bracket face to angled face, and align center screw to rail centerline.
- Position Foot Blocks and attach to rail using existing holes or pre-drill using 3/16" drill bit and attach with #8 x 2" coated screws.
 - For sections up to 6':** Place one Foot Block in the center of the rail.
 - For sections 6' to 8':** Space two Foot Blocks approximately at 1/3 intervals on the rail.

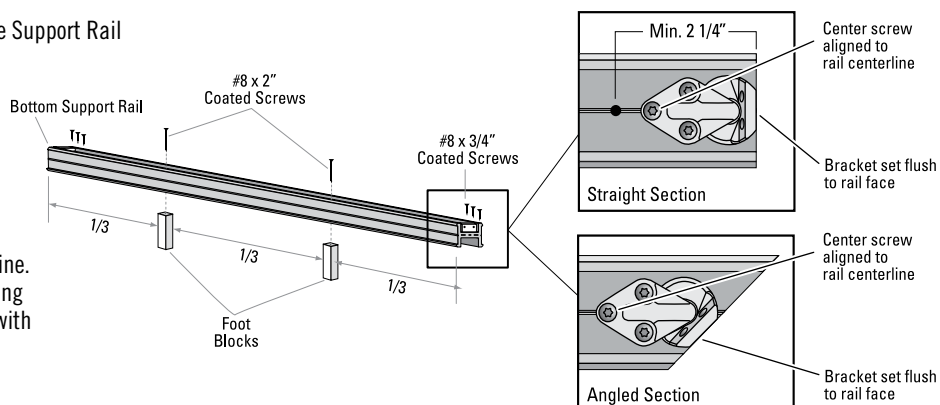

4 Install Bottom Support Rail

- Position Rail assembly onto Support Blocks.
- Pre-drill 7/64" pilot holes through Post Cover and into post through the holes in the Mounting Brackets.
- Secure brackets to posts with #8 x 3" green coated screws.

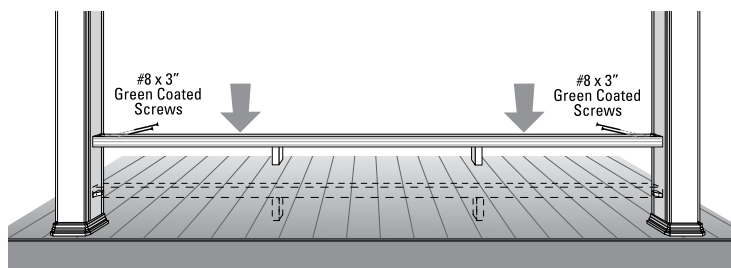

5 Space Baluster and Trim Rails

- Measure the distance between the posts at the bottom Support Rail.
- Transfer measurement to Bottom Rail. To maximize the Baluster spacing between the end Balusters and post, center the measurement on a pre-drilled hole or half way between two pre-drilled holes. The space between the end baluster and post can not exceed 4".
- Once the desired layout is achieved, trim the Bottom Rail to length.
- Measure the distance between the posts near the top of the post and repeat the Baluster layout process on the top Support Rail.

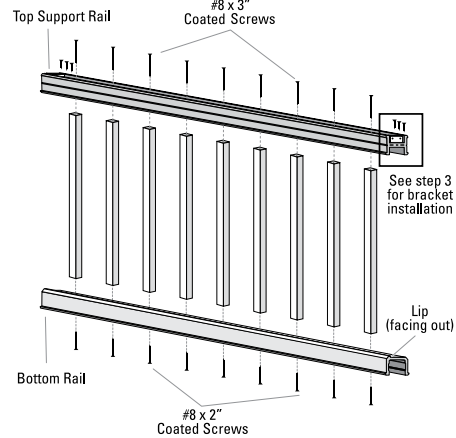

6 Assemble Baluster Section

- Position and secure Mounting Brackets at each end of the top Support Rail as outlined in Step 3.
- Lay out balusters along the top Support Rail, aligning them with the pre-drilled holes. Secure with #8 x 3" coated screws.
- Position Bottom Rail, using the lip to help align Balusters. Secure with #8 x 2 coated screws.
- Tip for Bottom Rail: Partially drive screws into all balusters before driving them in complete.

7 Install Rail Assembly

- Position rail assembly with lip on bottom rail toward outside of deck, over bottom Support Rail.
- Align top Support Rail to center of posts.
- Pre-drill with 7/64" drill bit and secure Mounting Brackets to Post Covers with #8 x 3" green coated screws.

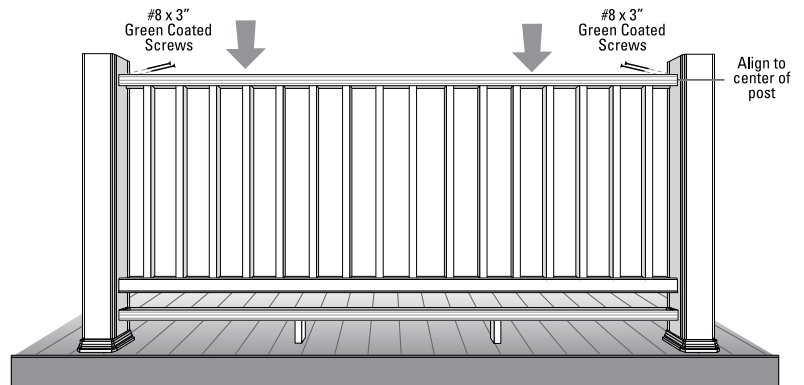

8 Install Top Rail & Post Caps

- Measure and cut Top Rail to length. Trim both ends to ensure a clean cut, may not be angled.
- Using a 3/16" drill bit, pre-drill 4 screw holes down through the top support rail. These will be used with 4-2" screws to attach the top rail as shown.
- Finish installation by positioning Post Caps, and secure using exterior grade caulk applied to the underside of the cap.

Caution: Screws must be 2" so they won't protrude through the Top Rail.

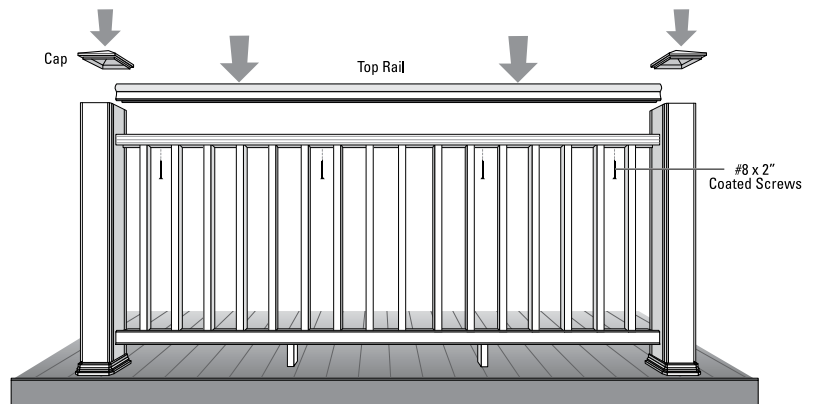

Installing Stair Rails - RadianceRail

- Consult your local building codes for guard and handrail requirements.

1 Install Post Covers

- Trim Post Covers to desired length. Note: Bottom post cover may be longer than standard length.
- Slide Post Cover and Post Skirt over post. Cover should slide easily over post, **DO NOT FORCE**.

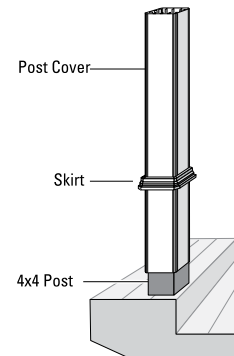

2 Trim Rails

NOTE: Support Rails are rotated 90° for stair rail applications.

- Check to ensure that posts and covers are plumb.
- Determine measurements and angle as shown in the diagram to the right.
- Trim both the top Support Rail and the bottom Support Rail to those dimensions. Test fit rails to check for accuracy.
- Transfer measurement from bottom Support Rail to Bottom Rail. To equalize the Baluster spacing between the end balusters and posts, center the measurement on a pre-drilled hole or half way between two pre-drilled holes. Trim Bottom Rail.
- Trim Top Rail to match top Support Rail.

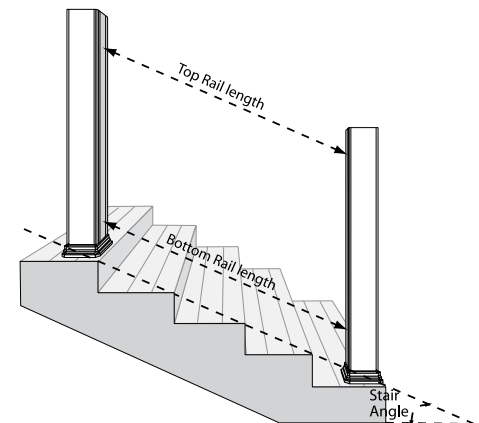
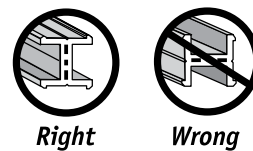

3 Drill Baluster Holes

It is necessary to drill Baluster screw holes in the top Support Rail.

- Place the Bottom Rail and the top Support Rail together as shown to keep the holes aligned.
- Drill 3/16" hole through the top Support Rail using the Bottom Rail holes for alignment, drilling at the same angle used to cut rail ends.
- Separate the two rails, once all holes are drilled.

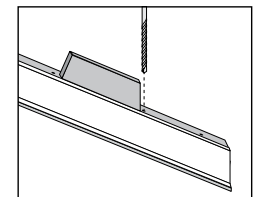
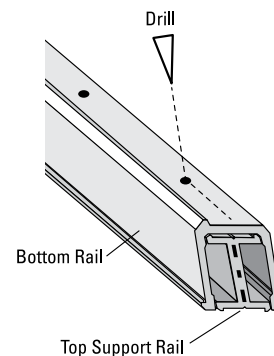

Note: Use a scrap piece of wood with the railing angle as a guide for your drill bit.

4 Assemble Balusters

- Trim Baluster ends to required angle as shown.
- Lay out Balusters along the top Support Rail aligning them with the holes drilled in step 3. Secure with #8 x 3" coated screws.
- Position Bottom Rail, using the lip to help align Balusters. Secure with #8 x 2" coated screws.
- Tip for Bottom Rail: Partially drive screws into all balusters before driving them in complete.

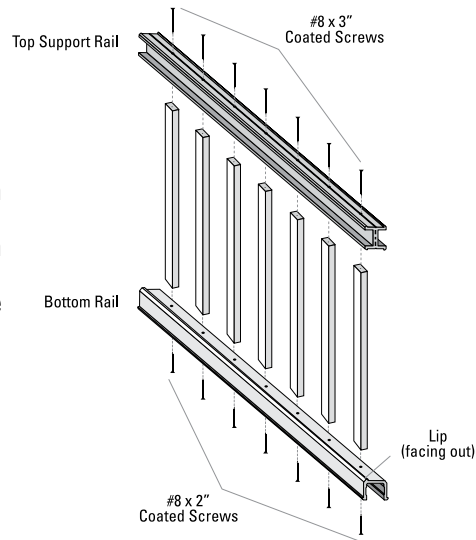

5 Install Lower Support Blocks

- Place Top Rail onto the railing assembly and measure the distance from top of the Top Rail to the bottom of the Bottom Rail. Transfer this dimension (A) to the post cover measuring down from the desired position of the Top Rail.
- Position a scrap piece of support rail that has been cut to the same angle of the stair on mark "A" and place a mark at location "B" (see B).
- Use the template as shown below to position Support Blocks. Support Block must be offset to the outside of the post.
- Pre-drill with a 7/64" drill bit and secure lower Support Blocks to post with #8 x 3" green coated screws. Align the angled face with the direction of the rail slope as shown.

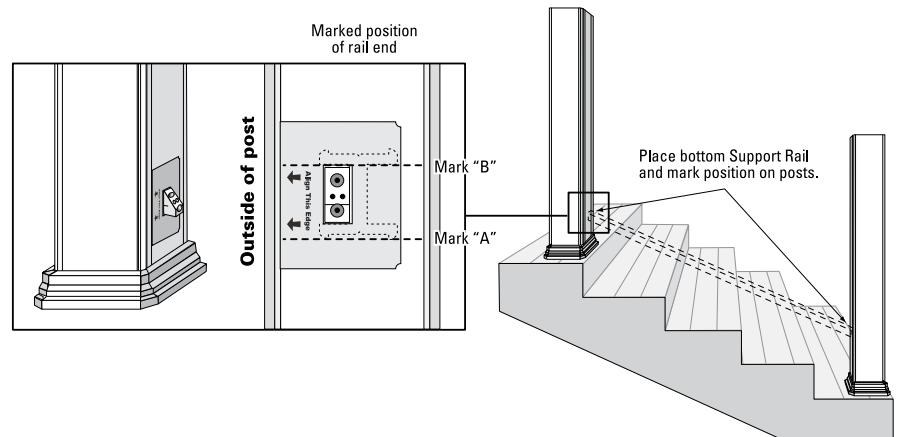

6 Install Bottom Support Rail

- Pre-drill with a 7/64" and attach Mounting Brackets to the inside of the bottom Support Rail at each end with #8 x 3/4" coated screws. Brackets must be installed to the stair tread side of the rail.
- Position Foot Blocks and attach to rail, pre-drill using 3/16" drill bit and attach with #8 x 3" screws.
- **For sections up to 6':** Place one Foot Block approximately in the center of the rail.
- **For sections 6' to 8':** Space two Foot Blocks approximately at 1/3 intervals on the rail.
- Position bottom Support Rail between post and pre-drill 7/64" pilot holes through Post Cover and into post through the holes in the Mounting Brackets.
- Secure Mounting Brackets to posts with #8 x 3" green coated screws.

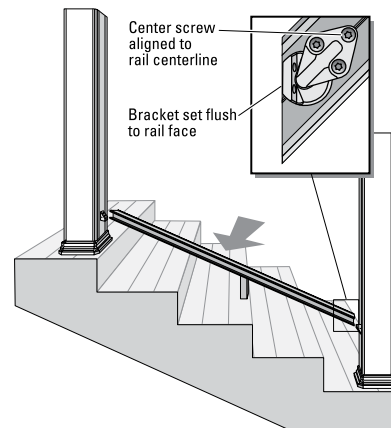

7 Install Rail Assembly

- Position rail assembly over bottom Support Rail, and align top Support Rail to center of posts.
- Mark ends of top Support Rail. Gently push top Support Rail to the side to obtain necessary clearance to attach Support Blocks.
- Attach Support Blocks in marked position. Pre-drill with 7/64" pilot holes and secure with #8 x 3" green coated screws.
- Swing rail assembly back against Support Blocks. Pre-drill 7/64" pilot holes and secure Mounting Brackets to posts with #8 x 3" green coated screws.

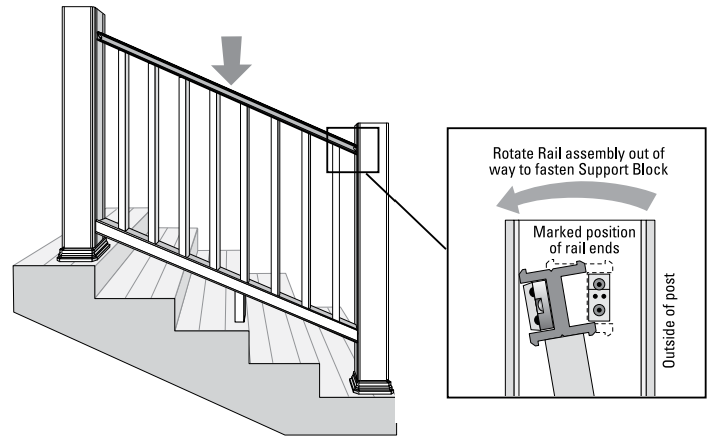

8 Install Top Rail & Post Caps

- Position Top Rail over Support Rail. Secure near each end and along the middle with #8 x 2" coated screws angled upward between the Balusters.
- Position Post Caps and secure using exterior grade caulk applied to the underside of the cap to finish installation.

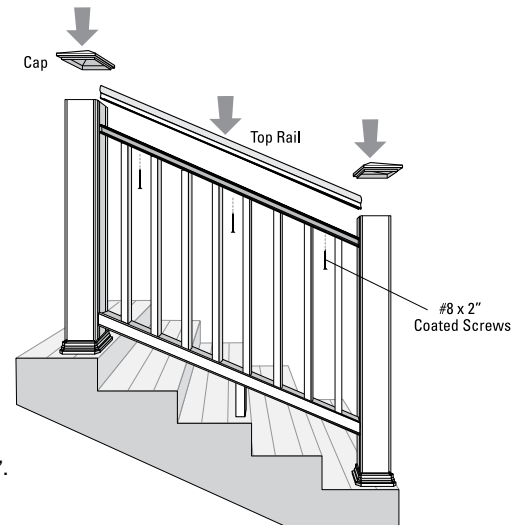

RadianceRail® Express System

Visit www.timbertech.com/installation to view TimberTech installation videos.

- Consult your local building codes for guard and handrail requirements.

RadianceRail Express kits are available in 6' or 8' lengths or 8' stair lengths.

Measure Your Railing Area

- Measurements are from edge to edge of posts. Rails are produced to 92.75" and 68". Maximum finished rail length must not exceed 91.75". Please allow for finished end cuts and angles when selecting rail length.
- Determine how many 6' or 8' RadianceRail Express Packs you need and check to be sure you have all the components (and quantities) listed in the chart and shown below.

Important Information

- RadianceRail Express packs are designed to not exceed 6' and 8' on center of post to center of post, respectively. For angled and stair runs center to center post spacing will be less than 6' or 8'.
- Stairs require 42" long balusters to trim to size.
- 4x4 lumber posts or TimberTech Secure Mount Post should be installed plumb.
- Cut slowly, using a fine tooth saw blade to avoid chipping.

Component Dimensions

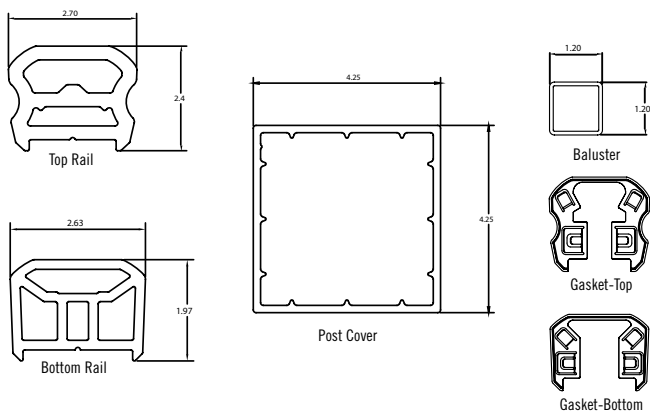

Components Needed For Installing One RadianceRail Express System			
Components available in Rail Packs, Baluster Pack and Stair Pack	RadianceRail Express Rail Pack	1 - Top Rail 1 - Bottom Rail 1 - Hardware Mounting Kit Foot Blocks - 1 in 6' Kits - 2 in 8' Kits 4 - Gaskets for 90° cuts only T-25 Torx driver bit	RadianceRail Express Stair Pack 1 - Top Rail 1 - Bottom Rail 1 - Stair Hardware Mounting Kit 2 - Foot Blocks T-25 Torx driver bit
	Baluster Pack	Square Balusters for 36" or 42" heights - 13 in 6' kits - 18 in 8' Kits - 36 kit - 29-3/4" height - 42" kit - 35-3/4" height *Stairs require 42" lengths	
Hardware included in Hardware Kits:	4 - Mounting Brackets 20 - 1-5/8" x #10 screws 2 - 3" x #10 Foot Block screws	Stair Hardware Kit	4 - Stair Mounting Brackets 8 - 1" x #10 screws 8 - 1-5/8" x #10 screws 2 - 3" x #10 Foot Block screws
Additional Components Needed for Each System	2 - Post Covers 2 - Post Caps 2 - Post Skirts		

Tools Required

- Miter Saw (blade designed for finish cuts)
- Drill
- 9/64" and 3/8" drill bits
- Tape Measure

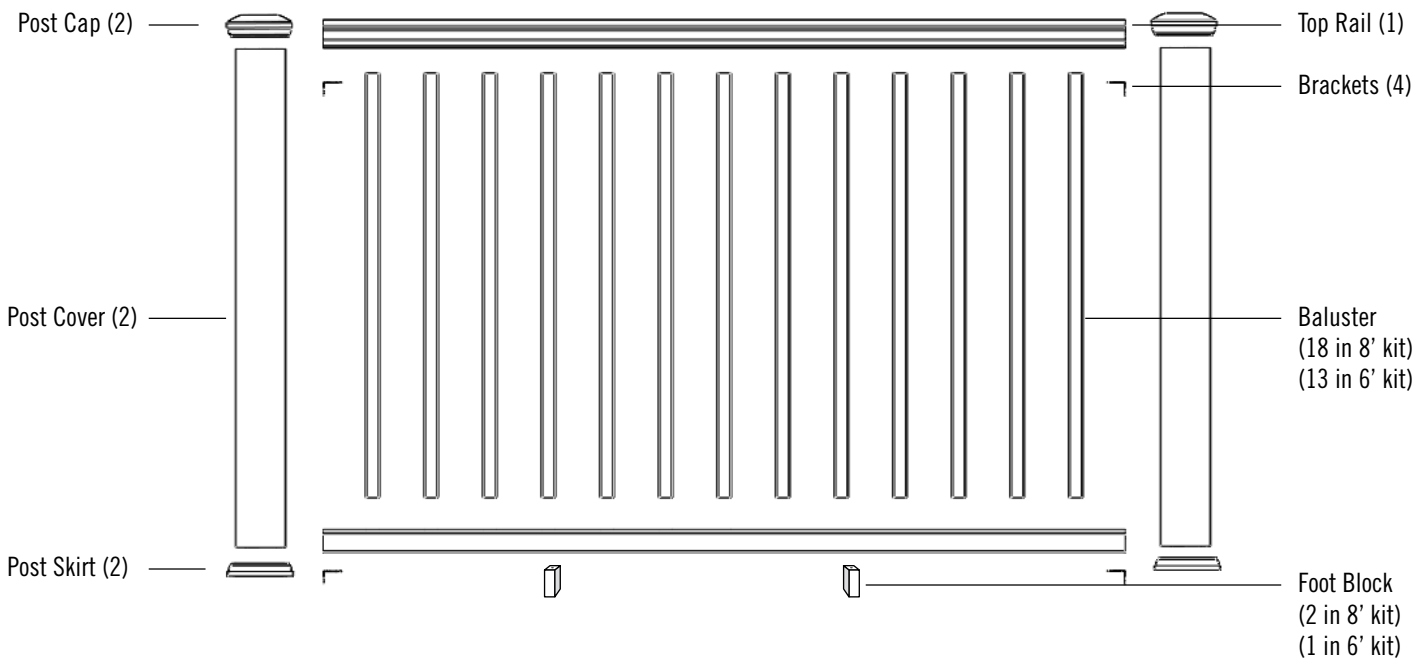

Installing Straight and Angled Rails - RadianceRail Express

1 Install Post Covers and Post Skirts

- Trim Post Cover to desired length. 38-1/2" above deck surface is optimal for 36" railing heights. If installing DeckLites please refer to the DeckLites installation Instructions.
- Slide Post Cover and skirt over post. Cover should slide easily over post. DO NOT FORCE.
- Using a level and shims plumb the post cover vertically. Taking the time to do this will make installation process much easier.

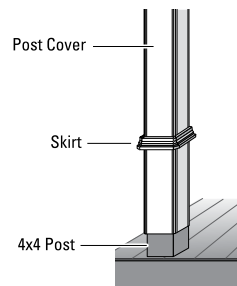

2 Cut and Pre-Assemble Bottom Rail

- Measure the distance between the posts covers near the bottom and top. For other than straight runs allow for any angled cuts. If using optional gaskets for 90° cuts, please cut rail 1/8" shorter for gasket clearance.
- To maximize the baluster spacing between the end balusters and post, center measurement on the pre-routed hole or halfway between two pre-routed holes. The space between the end baluster and the post must not exceed 3 3/4 inch or be less than 1 3/16" to the end of the rail for straight runs or 15/16" for angled runs. Cut the bottom rail to length.
- Use bottom rail to check the distance between the post covers near the top where the top rail will go. If the distance is the same transfer length and angle measurements to the top rail and cut to length. If the distance is not the same check post covers for vertical plumb and adjust as required. Or, add or subtract from the rail length to keep balusters vertically aligned.
- Position mounting brackets at each end of rail. Pre-drill through the 3 holes closest to the end of the rail with a 9/64" bit and attach with provided #10 x 1 5/8" screws.
For straight sections – align bracket centered on rail and within 1/16" of the end of the rail.
For angled sections – Brackets are designed so that a wing may be snapped off using a pair of pliers. Determine which wing needs to be removed based on the angled cut of the rail. Center and align within 1/16" of the end of rail.
- Using a 3/8" drill bit center and drill a 1 1/2" deep hole from one end of each foot block. From the other end center and drill a 9/64" through hole. Attach from the underside of the bottom rail using a 3.5" screw. Foot block can be mounted from the top of the bottom rail through the pre-routed baluster hole in some cases if the foot block is located under a baluster.
- Sections up to 6' require one foot block mounted in the center of the rail.
- Sections from 6'-8' require two foot blocks at 1/3 intervals.

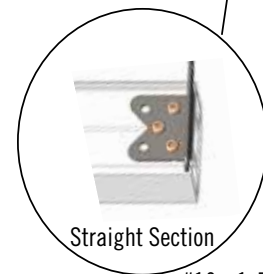
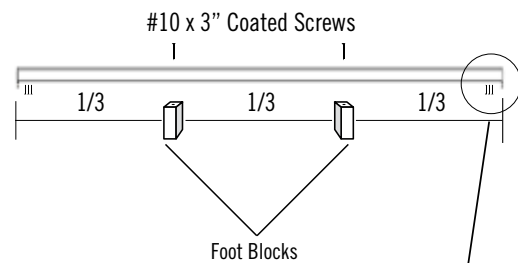

3 Install Bottom Rail

- Position assembly between posts.
- Insure rail is level and pre-drill 9/64" pilot hole through mounting bracket holes on one end.
- Add optional gasket (if wanted) to rail ends and secure bracket to post with provided #10 x 1 5/8" and re-check level. Pre-drill and attach opposite end of bottom rail using same method.

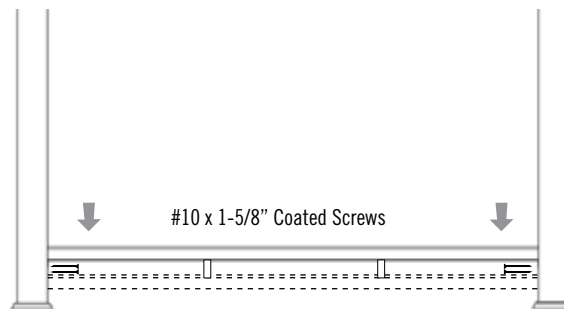

4 Assemble Top Rail

- Cut top rail based on measurements and balusters spacing from bottom rail.
- Brackets are designed so that wings may be snapped off using a pair of pliers if needed. Determine which wing(s) needs to be removed based on angle cut of the rail and baluster clearance. Center and align within 1/16" of the end of rail.
- Pre-drill through the 3 holes of the bracket closest to end of rail with a 9/64 bit and attach to top rail with provided #10 x 1 5/8" screws.

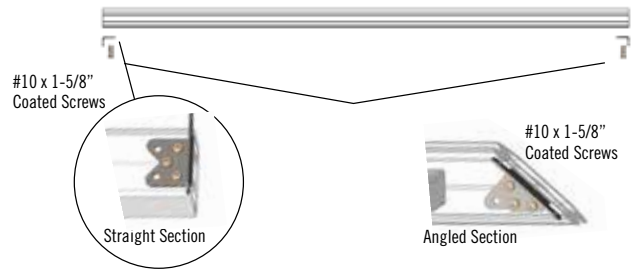

5 Install Balusters and Top Rail

- Straight sections (see below for angled sections).
- Place one baluster in the routed hole at each end of the bottom rail.
- Place top rail on those two balusters and attach gasket (if wanted) and bracket to post on one side.
- Working from the attached end place all remaining balusters in bottom rail, then into top rail by lifting the unattached end slightly.

Installation Tip:

- Do not fully engage the 4th to last baluster in the bottom rail – insert it into the top rail and then rest it next to the routed hole. This position slightly elevates the top rail.
- Install the last 3 balusters by first inserting them into the top rail, then the bottom rail.
- Slide the baluster that you left next to the routed hole into the bottom rail, allowing the top rail to drop into place.
- After all balusters are in place, attach remaining gasket and bracket to post, with provided bracket and screws after pre-drilling.

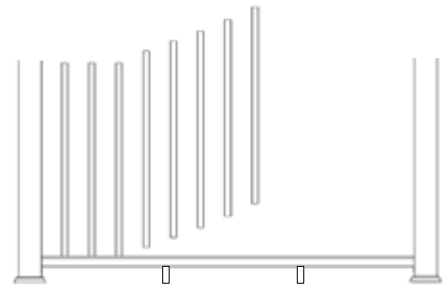

Angled sections

- Place balusters into bottom rail leaving out the last baluster at each end to allow for clearance to attach top rail bracket to post at each end. Pre-drill post cover through the two bracket holes and attach with provided 1 5/8" screws.
- Once attached to the post unscrew **the top rail from the bracket** at one end. Slightly lift the top rail and insert the last baluster. Lower the top rail back into place and re-attach the top rail using a minimum of two screws. Repeat at the opposite end.

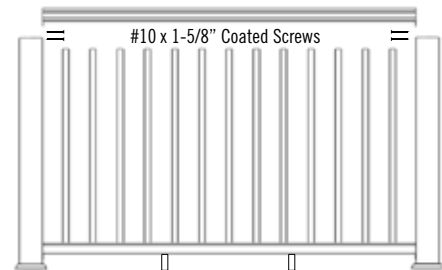

6 Install Post Caps

- Position Post Caps and secure using exterior grade caulk applied to the underside of the cap to finish installation.

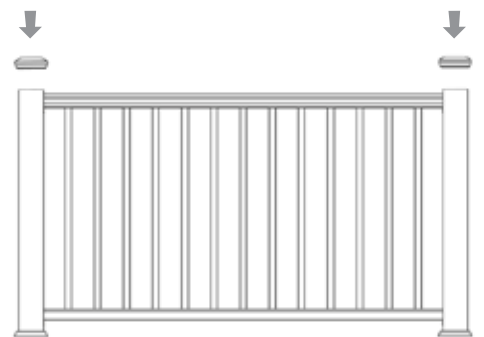

Installing Stair Rails - RadianceRail Express

• Consult your local building codes for guard and handrail requirements. RadianceRail Express stair rail and brackets are built at a nominal 34 degrees and may require adjusting of the bracket within the range of 32 to 34 degrees.

1 Install Post Covers

- Post on stair rails may need to be longer than straight runs. Lay out stair runs then cut to desired length.
- Using a level and shims plumb the post cover vertically. Taking the time to do this will make installation process much easier.
- Install post covers and skirts.

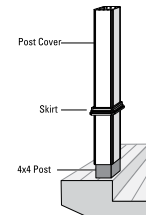

2 Cut Bottom Rails

- Measure the distance along the stair run between the posts covers near the bottom and top and rough cut the top and bottom rails to length. Remember to allow extra for the angled cuts.
- Lay the bottom rail along the stair tread as shown. Position rail to maximize distance between the last cut hole and the post at each end. The space between the last baluster hole and the post must not be less than 1-1/4" as measured along the rail. Transfer the length and angle of cut to the bottom rail and cut to finished length.

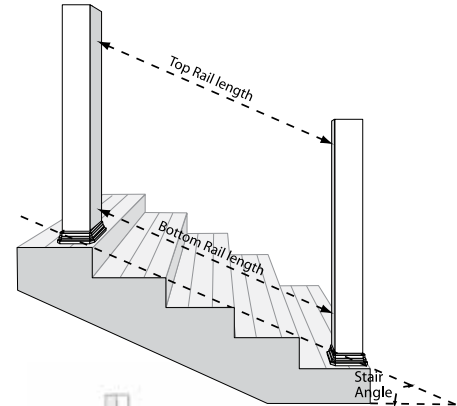

3 Cut Top Rail

- Use bottom rail to check the distance between the post covers near the top where the top rail will go. If the distance is the same transfer length and angle measurements to the top rail and cut to length. If the distance is not the same check post covers for vertical plumb and adjust as required or add or subtract from the rail length to keep balusters vertically aligned.

4 Install Bottom Rail

Note: Please consult local building code requirements for proper guard height before proceeding.

- Position brackets within 1/16" from end of rail. Pre drill using a 9/64" drill bit and attach brackets using #10 x 1" screws at the bottom of the stair run, and #10 x 1-5/8" screws at the top of the stair run.
- Place bottom rail in place and mark location for foot blocks. Rails 6' in length or less require one block at center of run. Rails longer than 6' require two support blocks at approximately 1/3 intervals. Pre drill support blocks as you would for level rails then cut required angle to fit against the bottom rail and attach.

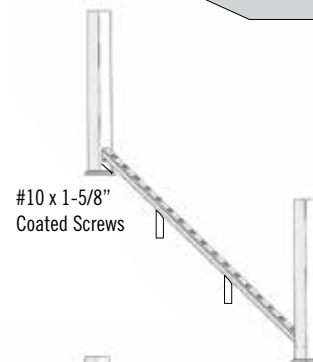

5 Cut and Install Balusters

- Using 42" long balusters cut ends to required length and angle to match the stair run.
- Install balusters into bottom rail.

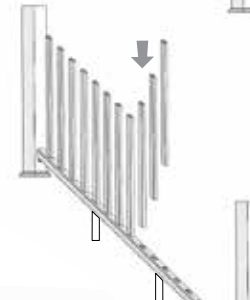

6 Install Top Rail

- Position brackets on top rail as shown and pre drill using a 9/64" drill bit. Attach brackets within 1/16" from end of rail using #10 x 1" screws at the bottom of the stair run, and #10 x 1-5/8" screws at the top of the stair run.
- Place top rail in position on one baluster at the top and bottom of the stair run. Pre drill and attach top rail at the bottom post only.
- Lift the top rail off the top baluster. Working from the bottom of the stair to the top, lower the top rail onto each baluster. Depending upon the length, you may need another person for assistance. Once balusters are fully seated in the holes, pre drill and attach the upper bracket.

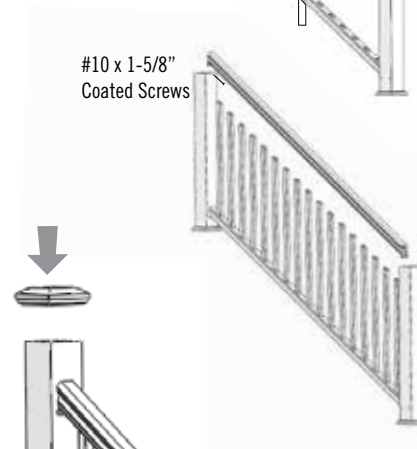

7 Install Post Caps

- Position Post Caps and secure using exterior grade caulk applied to the underside of the cap to finish installation.

Ornamental Rail System

Visit www.timbertech.com/installation to view TimberTech installation videos.

- Consult your local building codes for guard and handrail requirements.

Ornamental Rail kits are available in 6' or 8' lengths.

Measure Your Railing Area

- Determine how many 6' or 8' Ornamental Rail Kits you need and check to be sure you have all the components (and quantities) listed in the chart.

Important Information

- **Pre-drilling is required for all fastener locations.**
- Heights specified in this guide are for 36" residential use.
- Prior to installation it is recommended that you consult your local building codes.
- Protective clothing and safety glasses are recommended.
- For all TimberTech products, standard woodworking tools may be used.
- As with any outdoor product, periodic cleaning is recommended.

Components Needed For Installing One Ornamental Rail System	
Components Included in 6' and 8' Kits	1 - Ornamental Top Rail 2 - Universal Rails
	Screw Kits 6' Kit: (44) #8 x 3-1/2" Screws (6) #10 x 3-1/2" Flathead Screws 8' Kit: (55) #8 x 3-1/2" Screws (6) #10 x 3-1/2" Flathead Screws
	T-20 torx driver bit
Additional Components Needed for Each System	2 - Post Covers
	2 - Post Caps
	2 - Post Skirts
	One Baluster Kit for each section: 1 - 6' Baluster Kit - 15 Balusters or 1 - 8' Baluster Kit - 20 Balusters 36" Kit - 27" Baluster height 42" Kit - 33" Baluster height

Component Dimensions

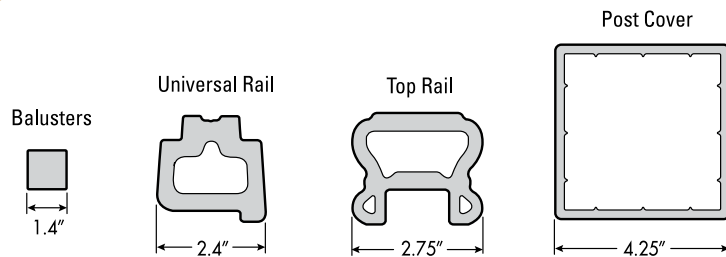

Tools Required

- Miter Saw
- Drill
- 3/16" drill bit
- Tape Measure

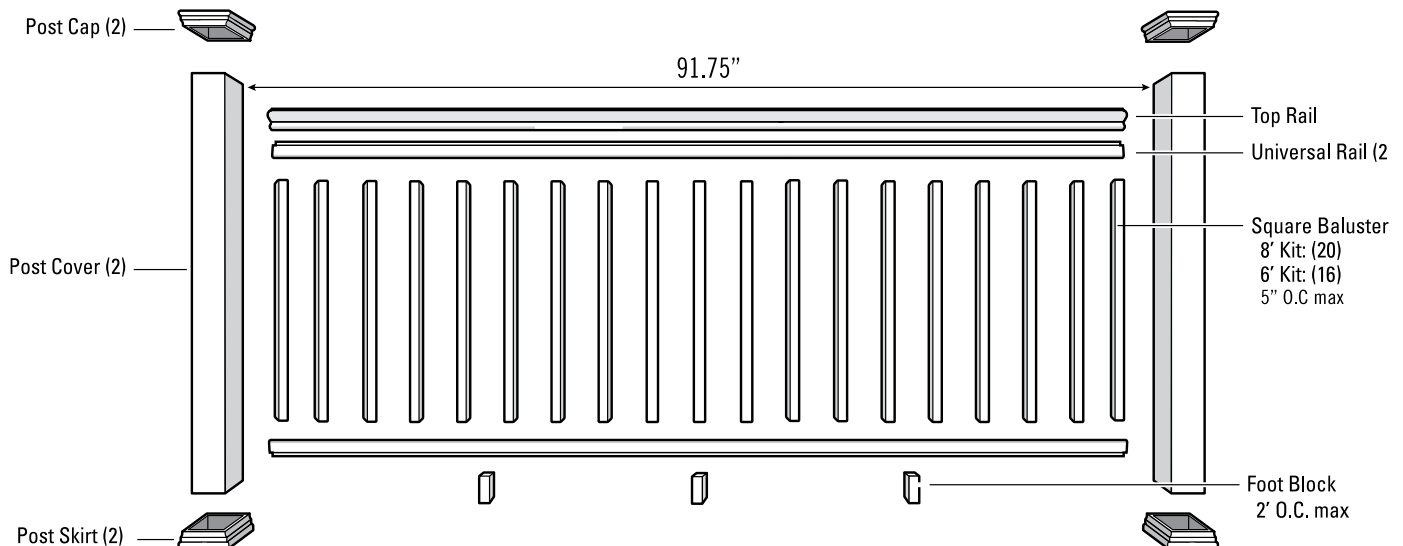

Installing Straight and Angled Rails - Ornamental Rail

- Consult your local building codes for guard and handrail requirements.

1 Prepare Posts

- Posts must be positioned no more than 8' on center for 8' kits or 6' on center for 6' kits, and must be plumb.
- Trim 4x4 post to a minimum of 37" above finished deck surface. *If installing DeckLites see page 30 for post component heights.
- Trim Post covers to desired length. For best results use a miter box.
- Slide Post Cover over 4x4 post. Do not force Post Cover over Post.
- Slide Post Skirts over Post Cover. (You will not be able to install Post Skirts once railing is installed.)
- Center one baluster on each post face that will receive a rail. Position the bottom of the baluster 5" from the deck surface and attach with #8x 3-1/2" screws.

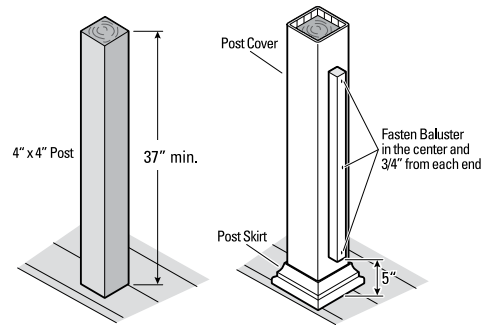

2 Prepare Rail

- Take measurements between posts for top and bottom rails and transfer these dimensions to the Universal Rails. (If you are installing an angled section, measure rail angle and transfer to Universal Rails.)
- Keep in mind when transferring measurements that the Baluster Retaining Lip on both rails must be installed so that they face the outside of the deck.
- In order to achieve even baluster spacing, center the measurement on a pre-drilled hole or half way between two holes. (Remember to take into account the 2 post mounted balusters.)
- The Universal Rails are pre-drilled for proper baluster spacing. If you find that the pre-drilled holes will not give you a balanced look, you may re-space the balusters as necessary. If you decide to alter the spacing, you will need to pre-drill with a 3/16" drill bit. **Baluster spacing must not exceed 5" from center to center.**
- Once the layout has been determined, trim Universal Rails to length.
- Attach balusters to Universal Rails using the #8 x 3-1/2" screws. Make sure to keep the Baluster Retaining Lip facing the outside of the deck.

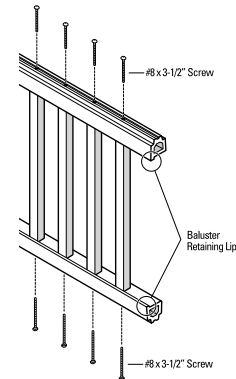
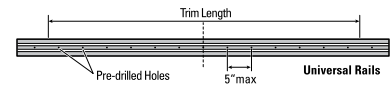

3 Attach Rail Assembly to Posts

- Once the main rail assembly is complete, slide it over the post-mounted Balusters. The Baluster retaining lip on the Universal Rails must be installed to the outside of the deck.
- Using a 3/16" drill bit to drill pilot holes at 30° from horizontal and approximately 1 1/4" to the side, starting 1 1/4" from the end of the rail.
- Secure the rail assembly to the post by driving #10 x 3-1/2" flathead screws through the pilot holes into the post. Do not bury the screw heads fully into the Universal Rail, leave one half of the screw head above the surface.

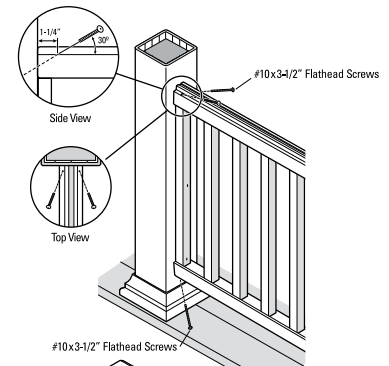

4 Attach Top Rail & Foot Block

- Pre-drill through the Universal at first baluster space and every fourth baluster space thereafter with a 3/16" drill bit. Place Ornamental Top Rail and secure with #8 x 3-1/2" screws as shown.
- Measure and cut Foot Blocks from the end of a spare Baluster. Position Foot Blocks every 2' on center. Pre-drill Universal Rail with a 3/16" drill bit and secure with #8 x 3-1/2" screws as shown.

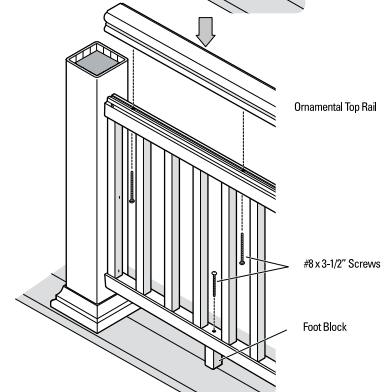

5 Install Post Caps

- Place Post Caps over post covers and fasten with stainless steel finish nails or exterior caulk.

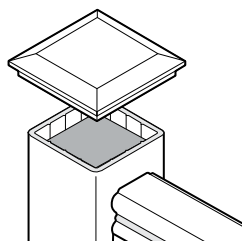

Installing Stair Rails - Ornamental Rail

• Consult your local building codes for guard and handrail requirements.

1 Prepare Posts

- Trim post and Post Cover to desired height based on angle of stair. Install Post Cover and Post Skirt.

2 Prepare Rails & Balusters

- Determine the angle of the stair rail, then measure the distance between posts for top and bottom Universal Rail. Transfer these dimensions as well as the angle of the rail to the Universal Rails.
- Determine Baluster spacing as outlined in the *Preparing Rails* section of the Straight Rail instructions. Once you are satisfied with the baluster spacing and rail lengths, trim Universal Rails to length.
- Pre-drill the Baluster holes in the Universal Rails at the same angle as the stair. It may be helpful to cut a piece of scrap wood to the desired angle and use it as a guide.
- Trim the balusters to the required length by cutting the stair angle at each end.
- Attach Balusters to the Universal Rails using the #8 x 3-1/2" screws. Make sure to keep the Baluster Retaining Lip to the same side.
- Attach a pre-trimmed Baluster to the post using three #8 x 3-1/2" screws.

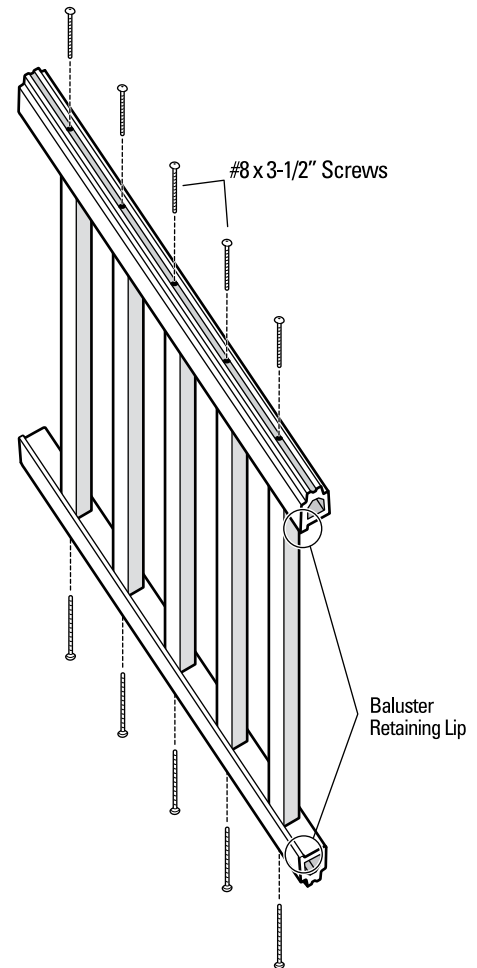
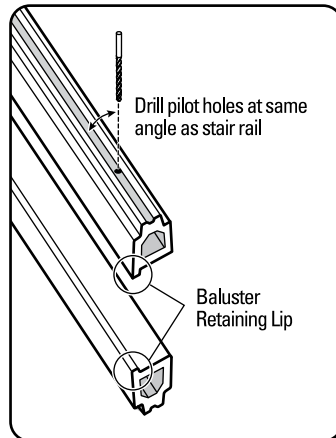
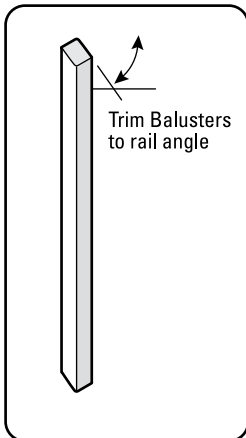
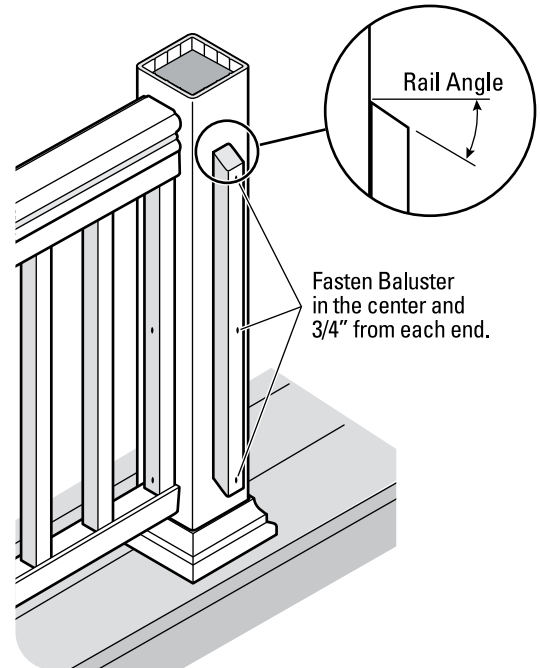

3 Install Rail Assembly

- Slide Rail Assembly between posts and let it rest on the post mounted Balusters.
- Secure rails to post by pre-drilling $3/16$ " holes through the rail $1-1/4$ " from the end, as shown.

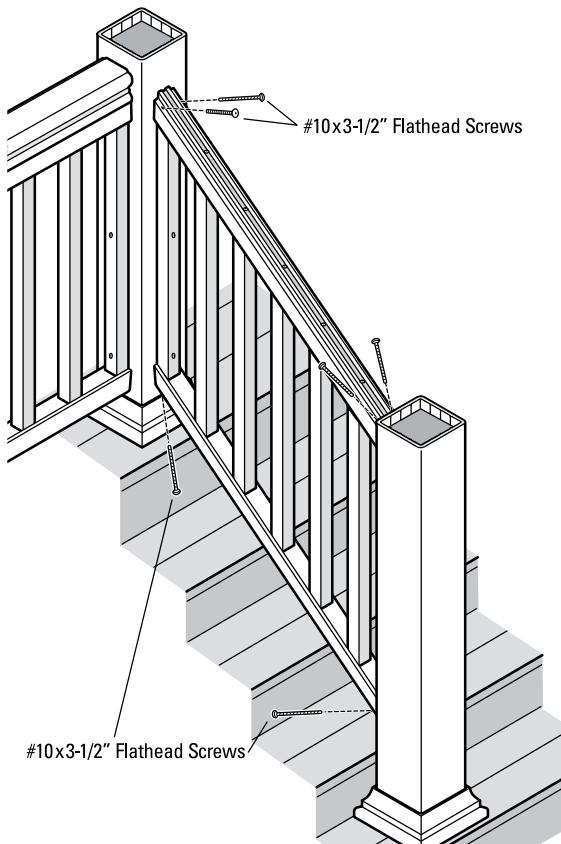

4 Install Top Ornamental Rail

- Trim the Top Ornamental Rail to the dimensions and angle of the top Universal Rail.
- Place Ornamental Top Rail in place. Pre-drill and secure at the first baluster spacing from each end and every fourth space thereafter with #8 x 3-1/2" screws as shown.

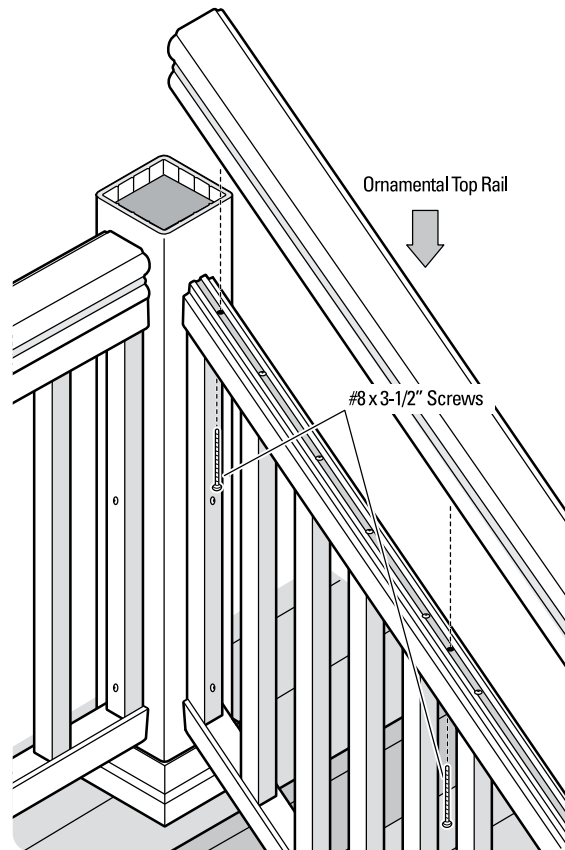

5 Attach Foot Blocks

- Determine the location of the Foot Blocks (they should be spaced 2' on center.) Measure the distance between the step and the bottom of the rail. Cut a Foot Block from the end of a spare baluster to the desired angle and length. Footblocks must be used.
- Pre-drill and secure Foot Block to the bottom Universal Rail using a #8 x 3-1/2" screw.

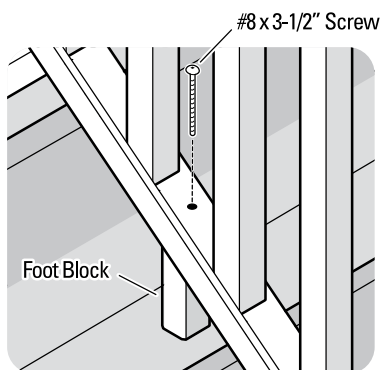

6 Install Post Caps

- Place Post Caps over post covers and fasten with stainless steel finish nails or exterior caulk.

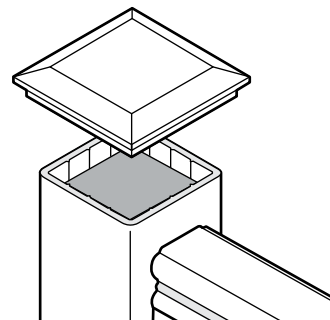

BuilderRail® System

Visit www.timbertech.com/installation to view TimberTech installation videos.

- Consult your local building codes for guard and handrail requirements.

BuilderRail kits are available in 6' or 8' lengths.

Measure Your Railing Area

- Determine how many 6' or 8' BuilderRail Kits you need and check to be sure you have all the components (and quantities) listed in the chart.
- 6' and 8' sections should be measured from center-to-center of posts.

Important Information

- Prior to installation it is recommended that you consult your local building codes.
- **Pre-drilling is required for all fastener locations.**
- Heights specified in this guide are for 36" and 42" minimum rails.
- Post Skirts will not fit properly on the deck if your rail 4x4 posts are notched over the rim joist.
- Foot Blocks are to be constructed from end cuts of the BuilderBoard. Foot Blocks may also be purchased.
- Protective clothing and safety glasses are recommended.
- For all TimberTech products, standard woodworking tools may be used.
- As with any outdoor product, periodic cleaning is recommended.

Component Dimensions

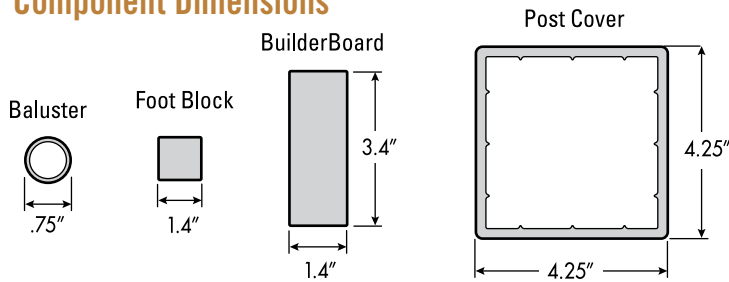

Tools Required

- Miter Saw
- Drill
- 3/16" drill bit
- 9/64" drill bit
- 1/2" drill bit
- Tape Measure

Components Needed For Installing One BuilderRail System	
Hardware included in 6' and 8' Kits *Stair Kits are sold separately in 8' lengths	Baluster Spacing Template
	Classic Metal Balusters 6' Kit: (15) 8' Kit: (20) 8' Stair Kits: (20) 36" Kit - 25" Baluster height 42" Kit - 31" Baluster height 23-3/4" height for 36" stairs 29-3/4" height for 42" stairs
	Hardware Mounting Kit Mounting Brackets (4) #8 x 3" Screws (8) #8 x 3/4" Screws (12)
	Baluster Connector Kit Connectors 6' Kit: (30) 8' Kit: (40) #10 x 2" Screws 6' Kit: (30) 8' Kit: (40)
Additional components needed for each system	2 - BuilderBoards
	2 - Post Covers
	2 - Post Skirts
	Deck Plank for Top Rail
	#8 x 3-1/2" Foot Block Screws
	TimberTech TOPLoc Face Fasteners or #8 x 2-1/2" Color Matched Top Rail Screws
	Foot Blocks 6' Kit: (2) 8' Kit: (3)

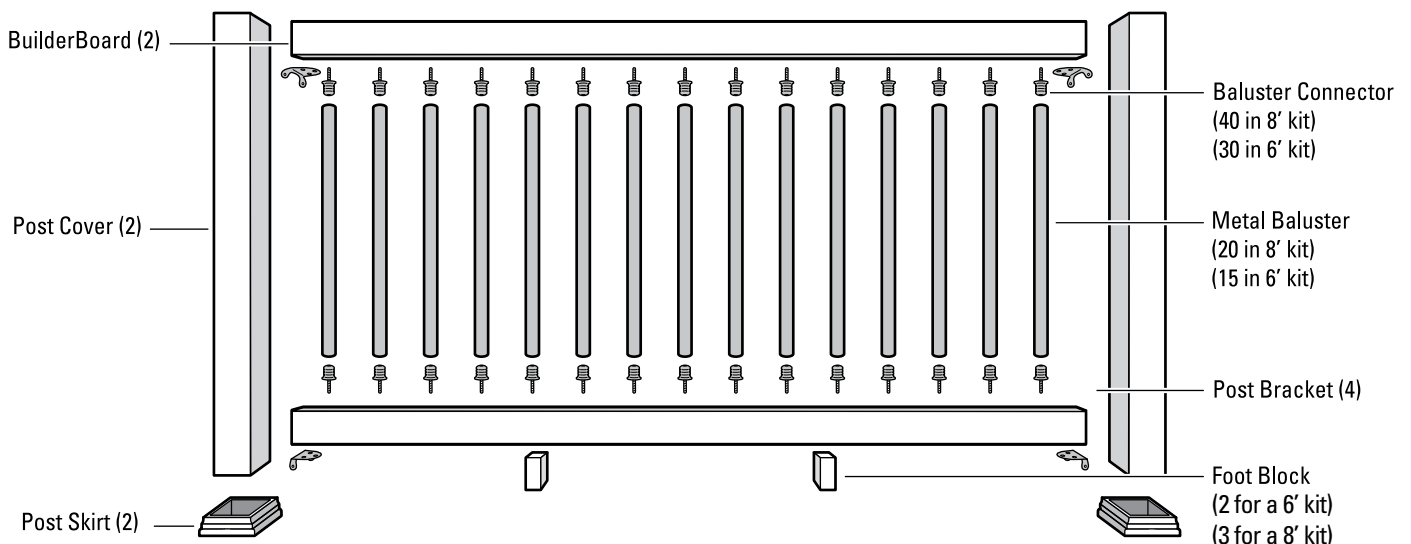

Installing Straight and Angled Rails - BuilderRail

1 Prepare Posts

- Posts must be positioned no more than 8' on center, and must be plumb.
- Trim 4x4 post to a height of 35-1/4" (for 36")/ 41-1/4" (for 42") above finished deck surface. Take care to make cuts as precise as possible.
- Trim Post covers to 35-3/8" (for 36")/ 41-3/8" (for 42"). For best results use a miter box.
- Slide Post Cover over 4x4 post. Do not force Post Cover over post.
- Slide Post Skirts over Post Cover. (You will not be able to install Post Skirts once railing is installed.)

Note: Post at base of stairs must be left long. See stair instructions on page 18.

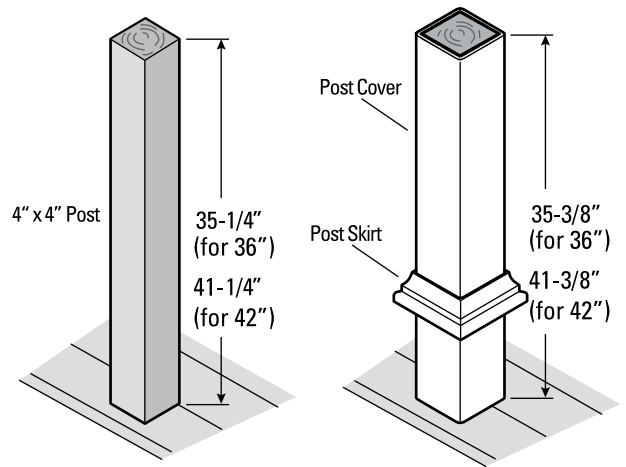

2 Prepare Rails

- Take measurements between posts for top and bottom rails. Trim BuilderBoard to these dimensions. (If you are installing an angled section, measure rail angle and transfer to BuilderBoards before cutting.)
- Lay the BuilderBoard rails side by side (narrow face up) and mark the center of each baluster position. **Balusters must not exceed 4-5/8\"**
- For convenience a suggested template is included in kit.

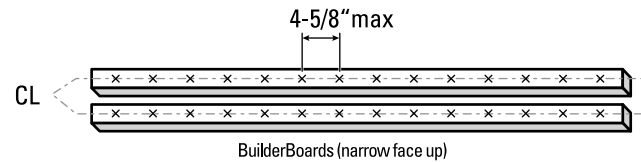

3 Attach Baluster Mounts and Post Brackets

- Drill 9/64" holes along the centerline of both BuilderBoards at the baluster marks. Holes should be approximately 1-1/4" deep.
- Attach Baluster Mounts at each pre-drilled location using the provided #10 x 2" screws.
- Position Post Brackets flush to the ends of the BuilderBoards. **Top Rail:** Position on same face as Baluster Mounts. **Bottom Rail:** Position on opposite face from Baluster Mounts.
- **Pre-drill** with 9/64" bit, and attach with the provided #8 x 3/4" screws.

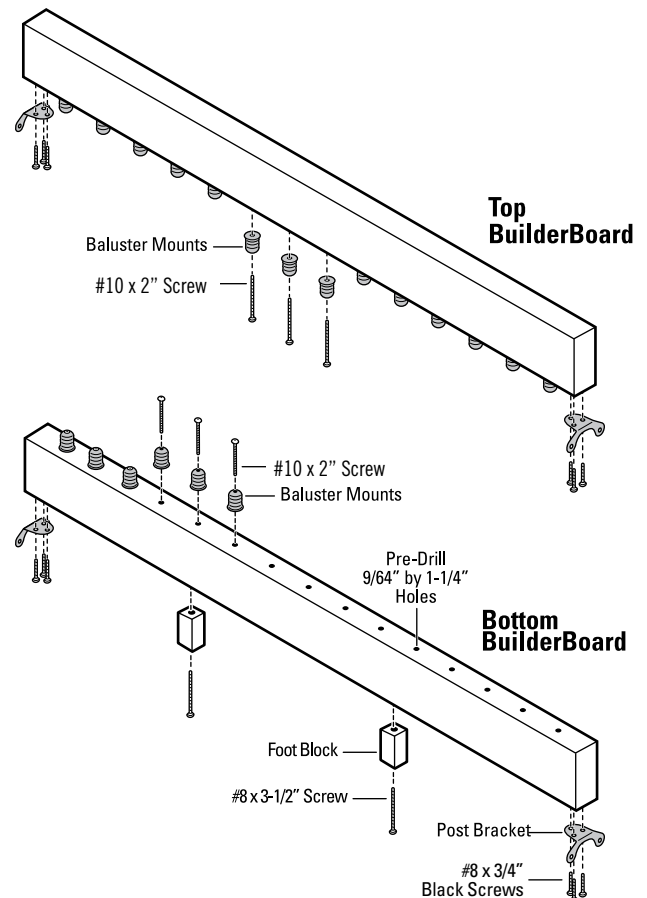

4 Attach Foot Blocks

- Install foot blocks approximately 2' on center along the underside of the bottom rail. 2 Foot Blocks are required for a 6' section, 3 for an 8' section.
- Foot Blocks are to be constructed from end cuts of the BuilderBoard. Foot Blocks may also be purchased.
- Prepare Foot Blocks by boring a 1/2" hole 1" deep in the bottom of the block, then drill the rest of the way through with a 3/16" bit.
- Attach the Foot Blocks to the BuilderRail using #8 x 3-1/2" screws.

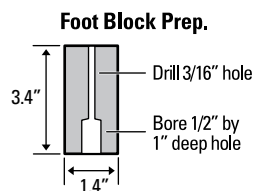

5 Install Bottom Rail & Balusters

- Place bottom BuilderBoard between posts, and align to center of post. Let BuilderBoard rest on the Foot Blocks.
- Pre-drill at Post Brackets with a 3/16" bit and attach with #8 x 3" screws. (note: pre-drill through Post Cover only, not into posts)
- Slide Balusters over the Baluster Mounts along the bottom BuilderBoard.

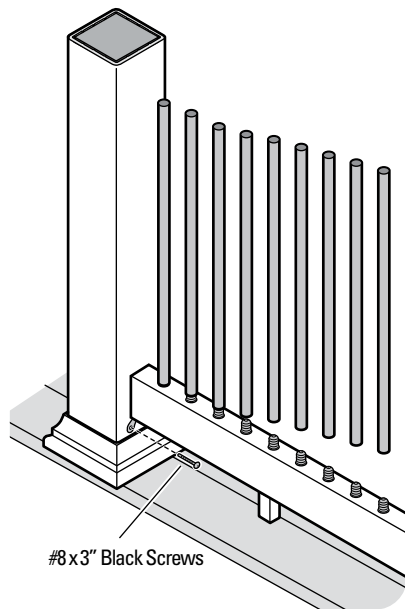

6 Install Top Rail

- Bring the top BuilderBoard into position and align each Baluster with its respective Baluster Mount.
- Tip: Start at one end with Top Rail angled upward. Work your way down the rail by aligning and lowering the Top Rail onto each baluster.
- Once all Balusters are in position, make sure they are snugly seated on the Baluster Mounts. The top of the top BuilderBoard should be flush with the top of the Post Cover.
- Pre-drill at Post Brackets with a 3/16" bit and attach with #8x3" color matched screws. (note: pre-drill through Post Cover only, not into posts.)

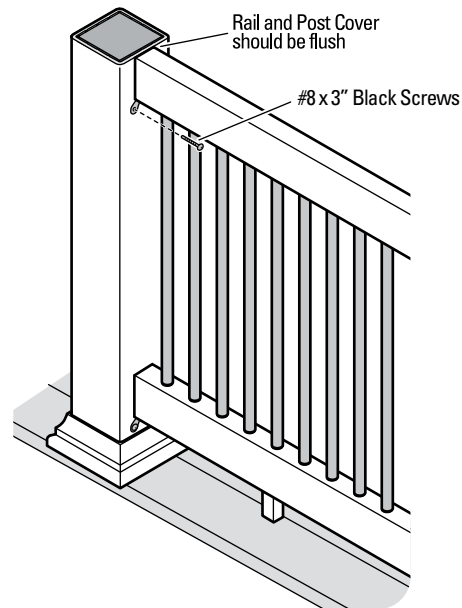

7 Install Cap Rail

- Finish off the railing system by applying one of TimberTech's solid plank profiles to the top of the rail.
- Cut the planking so that any seams fall at the center of a post. Miter the planks at corner posts.
- Pre-drill and secure planks at posts using 2 TOPLoc Face Fasteners or #8 x 3" screws positioned 3/4" from the end of each plank and 1-1/2" from the edge of each plank. Pre-drill and secure plank to the BuilderBoard every 2' using the same screws.

TIP: If your rail has stair sections, start installing the cap at the stairs and work your way around from there. Wait until all rail sections are complete before beginning cap installation.

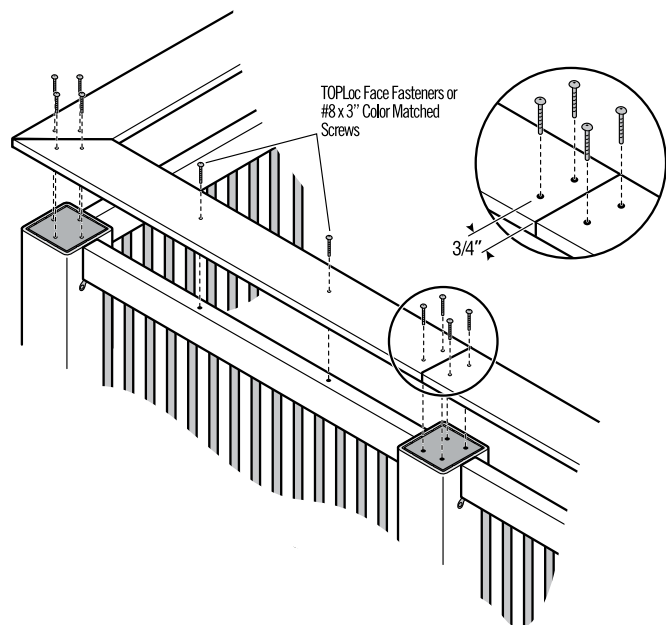

Stairs - BuilderRail



The BuilderRail Stair Kit includes angled Post Brackets and Baluster Mounts. These components are designed for a rail angle of 35° with a margin of adjustment of 5°. In order to insure proper installation, the angle of your stair rail should be as close to 35° as possible.



Angled Baluster Mount



Angled Post Bracket

- Consult your local building codes for guard and handrail requirements.

1 Trim BuilderBoard Rails

- Make sure your posts are no more than 8' on center, and plumb.
- Place a Post Cover over the lower stair post, DO NOT trim lower post or post Cover yet.
- Position a BuilderBoard on the stairs against the top and bottom Post Covers. Mark the length and angle on the BuilderBoard at each post.
- Trim the ends of the BuilderBoard to your marks.
- After checking fit at top and bottom rail locations, trim a duplicate BuilderBoard for the top rail.

2 Trim Bottom Post

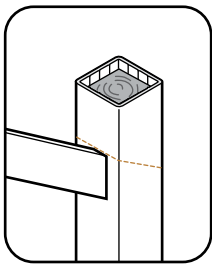

Position the top rail between the posts so that the top of the rail is flush with the top of the upper post.

Mark where the top of the rail meets the lower post. This marks the upper edge of the lower Post Cover.

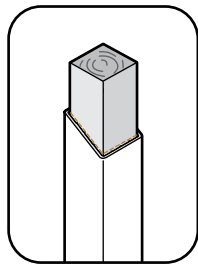

Remove the Post Cover and trim to the stair angle using your mark as a guide.

Re-position Post Cover over post and use it to mark the angle of the cut for the post.

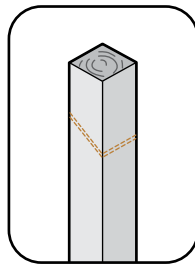

Remove Post Cover and using a straight edge, mark a parallel line about 1/8" below the lines made in the previous step.

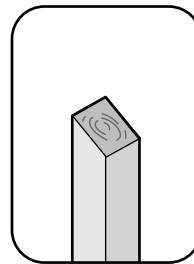

Using a circular saw, trim the post to the lower set of marks.

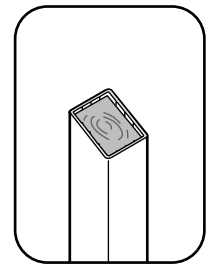

Replace the Post Cover and place a Post Skirt over the Post Cover.

3 Determine Position of Bottom Rail

- Create a mock-up of a rail section using a couple of scrap pieces of BuilderBoard (cut to the rail angle), two Baluster Connectors and a Baluster.
- Position the top rail flush with the top of the Post Cover and mark the top of the bottom rail on the post.
- Repeat for the bottom post making sure the rails are positioned properly to run up to the upper post.

4 Prepare Rails

- After BuilderBoard rails are trimmed to the length as detailed in step 1, you need to make a relief cut at the upper end of the rails to insure a proper fit for the upper post brackets. This only needs to be done on the upper ends of both top and bottom rails.
- Measure 3/4" along the angled cut and cut back from there at a 45° angle. This modification is not necessary at the low end of the rails.
- Lay the BuilderBoard rails side by side (narrow face up) and clamp them together.
- Make sure the angle cuts are oriented as shown and mark the locations for the baluster connections.
- Determine layout for Balusters and mark along the centerline of the BuilderBoards.
- For convenience, a suggested stair template is included in kit.

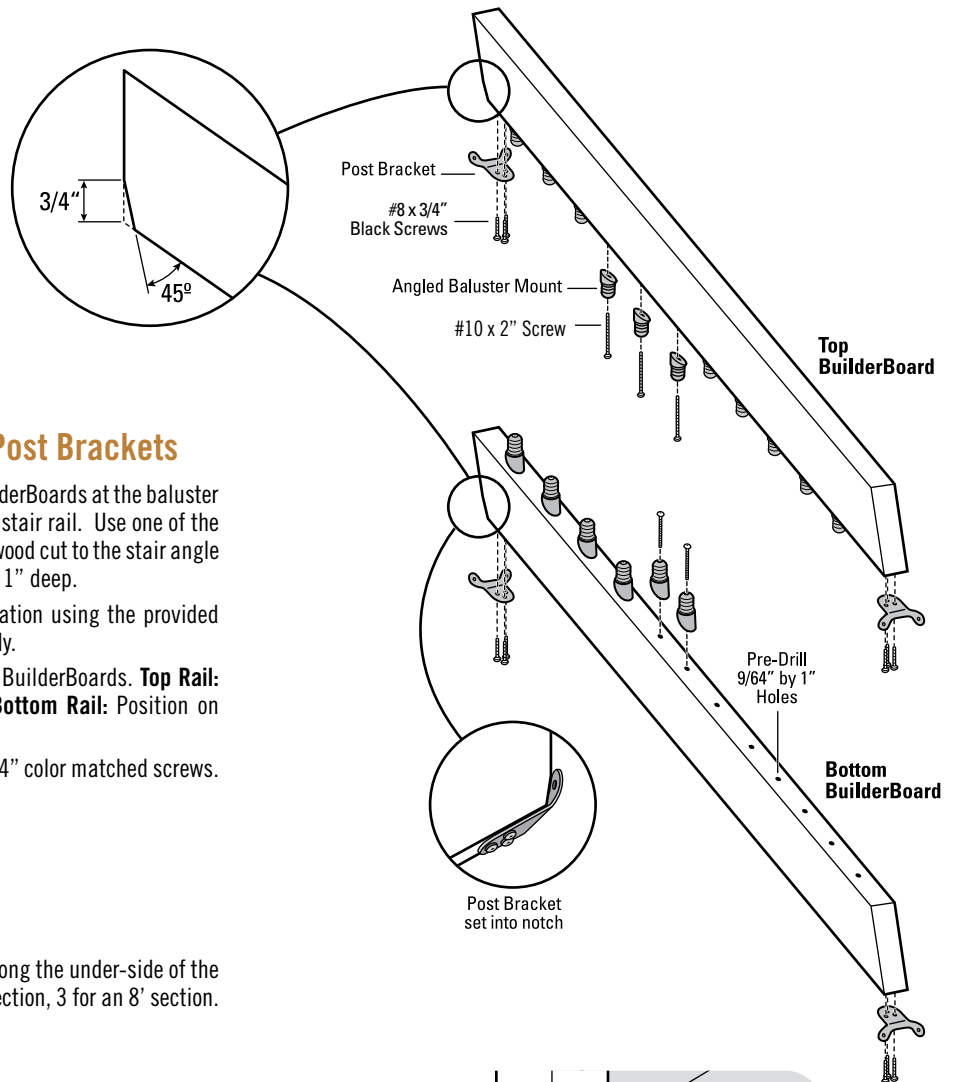
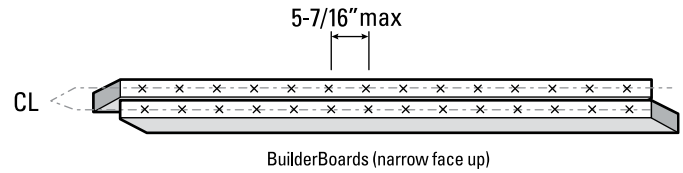

5 Attach Baluster Mounts and Post Brackets

- Drill 9/64" holes along the centerline of both BuilderBoards at the baluster marks. Holes must be drilled at same angle as stair rail. Use one of the angled Baluster Connectors, or a scrap piece of wood cut to the stair angle as a drill guide. Holes should be approximately 1" deep.
- Attach Baluster Mounts at each pre-drilled location using the provided screws making sure the angle is aligned properly.
- Position Post Brackets flush to the ends of the BuilderBoards. **Top Rail:** Position on same face as Baluster Mounts. **Bottom Rail:** Position on opposite face from Baluster Mounts.
- Pre-drill with a 9/64" bit and attach with #8 x 3/4" color matched screws.

6 Install Foot Blocks

- Install Foot Blocks approximately 2' on center along the under-side of the bottom rail. 2 Foot Blocks are required for a 6' section, 3 for an 8' section.
- Foot Blocks are to be constructed from end cuts of the BuilderBoard. Foot Blocks may also be purchased.
- Prepare Foot Blocks by boring a 1/2" hole 1" deep in the bottom of the block, then follow with a 3/16" hole through the whole block. Trim Foot Blocks to rail angle making sure to maximize the length.
- In order to position Foot Blocks, you will need to temporarily install the bottom rail. Pre-drill Post Cover at the bracket locations with a 3/16" drill bit. Pre-drill Post Cover only.
- Position Foot Blocks so that they fit snug between the bottom rail and the stairs, mark their location, then remove bottom rail.
- Attach the Foot Blocks at marked locations using #8 x 3-1/2" screws, then reinstall the bottom rail with the provided 3" screws.

Foot Block Prep

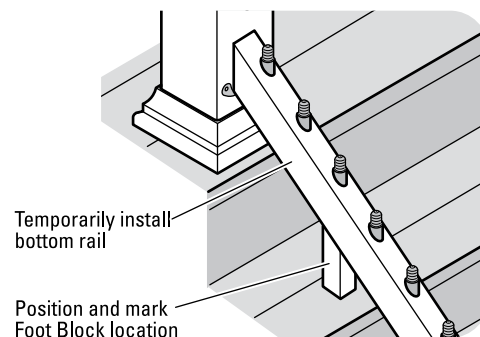
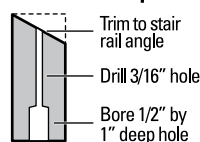

7 Assemble Rail Section

- Install the bottom BuilderBoard, securing it to the post at the brackets with #8 x 3" color matched screws.
- Place a Baluster over each of the Baluster Connectors along the Bottom BuilderBoard.
- Tip: Start at one end with Top Rail angled upward. Work your way down the rail by aligning and lowering the Top Rail onto each baluster.
- Next, bring the top rail into position, fitting each Baluster Connector into its respective Baluster. It is helpful to have two people perform this step.
- Pre-drill the post cover at the bracket hole locations with a 3/16" drill bit and secure the rails to the post with #8 x 3" color matched screws.

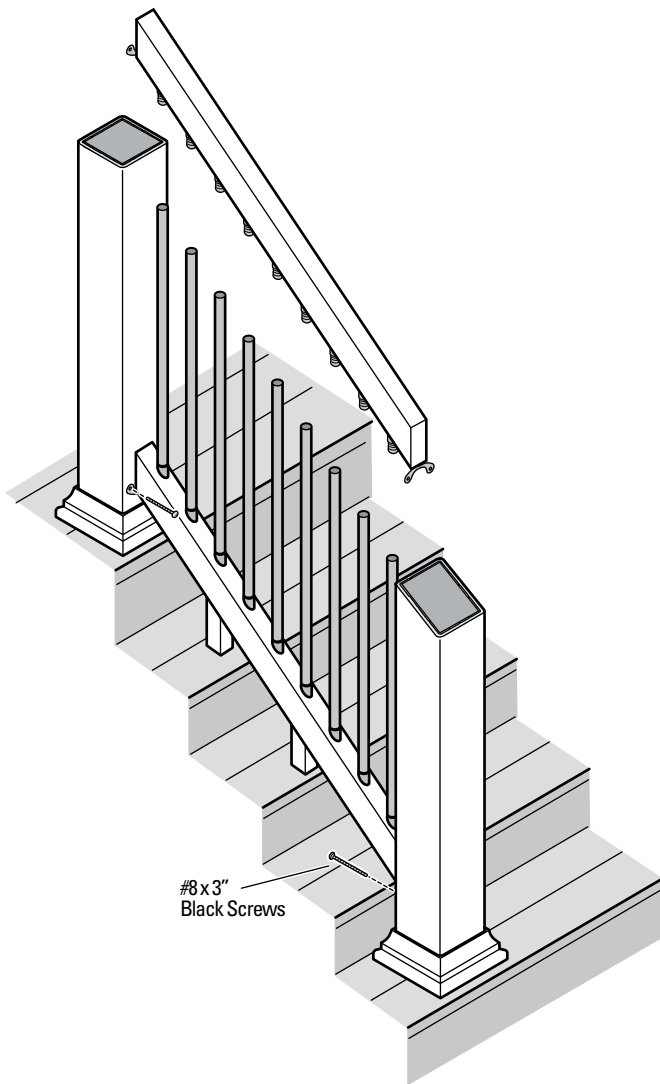

8 Install Cap Rail

- Finish off the railing system by applying one of the TimberTech solid plank profiles to the top of the rail. You may want to rout a bullnose edge on the end overhanging the bottom post.
- Pre-drill and secure planks at posts using 2 #8 x 3" screws positioned 3/4" in from the ends and 1-1/2" from the edge of the plank. Where planks fully cover a post without a seam, secure the plank with two screws set at 1-1/2" in from the sides of the plank and centered on the post. Pre-drill and secure plank to the BuilderBoard every 2' using the same screws.

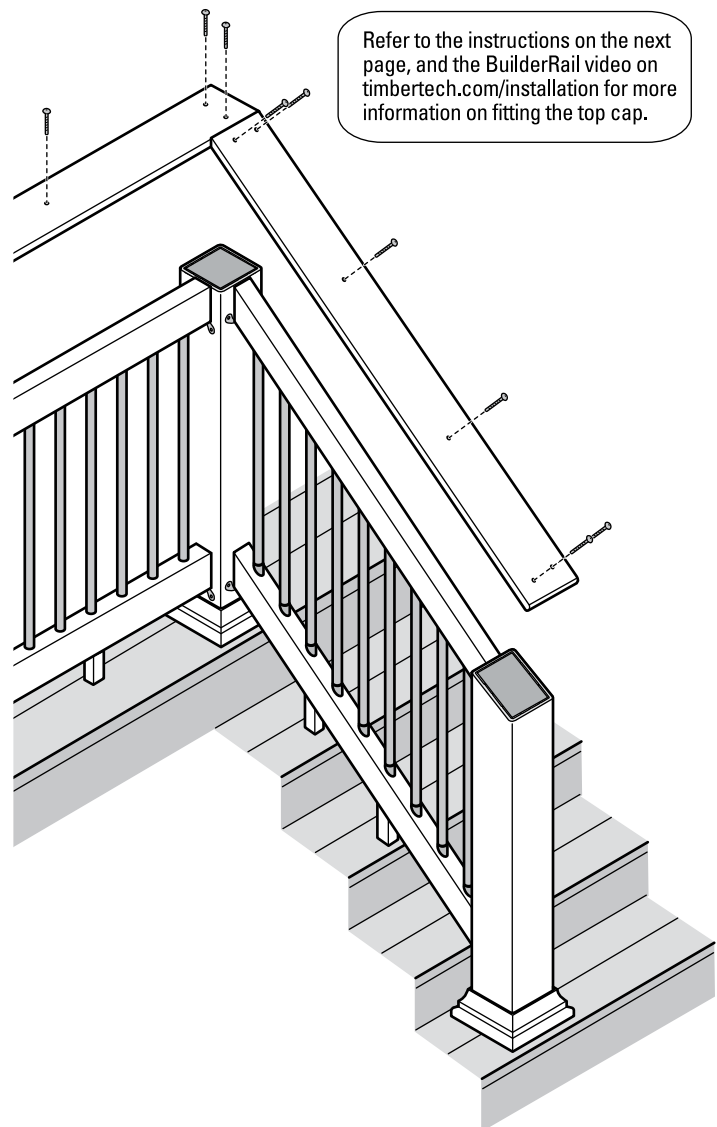

Cap Rail Details - BuilderRail

Transitioning from Stair Rail to Straight Rail

You will have to make some minor modifications to the cap planks in order to achieve an aesthetically pleasing transition from stair to straight rail sections.

The modifications required depend on the profile plank you are using. To watch a demonstration of these modifications, view the TimberTech BuilderRail video on timbertech.com/installation.

Solid Plank with Square Edge

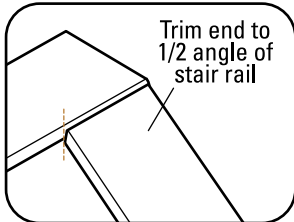

Trim the end of the plank that runs down the stair rail to 1/2 of the angle of the stair. Leave the plank long so that you can make adjustments later.

Place the planks in their finished position and mark where they come together.

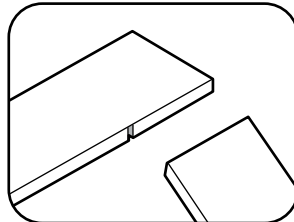

Cut a notch in the top plank at the mark where the two planks meet.

The notch should be angled at roughly 1/2 of the stair angle toward the underside of the plank, and should not penetrate the top surface of the plank.

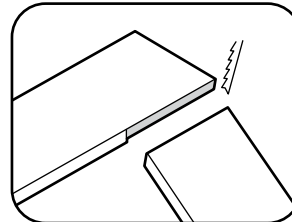

Using a jigsaw set to half the stair angle, cut along the side edge of the plank until you meet the notch you just cut.

Slide the joint together and check fit, adjust if necessary.

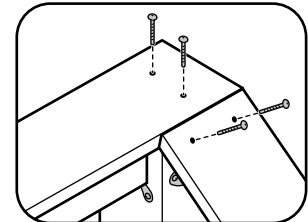

Cut the top planks to their final length. Make sure to allow some overhang beyond the post cover to finish the ends of the planks.

Attach the planks to the post with #8 x 3" screws. Start the screws 1-1/2" from the edge of the plank, and angle them so that they go into the post without being visible underneath.

Care & Cleaning

With proper installation and care, TimberTech products will provide years of outdoor living pleasure.

Storage

Store TimberTech products under cover to maintain a clean surface. If stored outdoors, they must be covered with a non-translucent material.

- All products should be stored flat and on a dry surface.
- Stack units with banding and bottom supports aligned.

Discarding Scrap Product

Scrap can be discarded with normal construction debris.

Care & Cleaning

Basic Cleaning Recommendations

Although TimberTech products are low-maintenance, TimberTech recommends periodic cleaning to help maintain the beauty of the product. For best results a cleaner like eco-friendly Corte Clean (corteclean.com) is recommended. Follow the manufacturers' application instructions.

A power washer can be used when cleaning your TimberTech products. The recommended maximum pressure is 1500psi. A fan tip nozzle should be used along with the proper cleaning product. Spray in the direction of the brush/grain pattern to avoid damaging the product. Use caution not to damage the material and always take the proper safety precautions when operating a power washer.

Ice and Snow

For ice removal, either rock salt or calcium chloride may be used without damage to the surface. However, either of these products may leave a white residue, which may be removed by either rinsing with water, or a mild soap/water solution.

Dirt, Grime, Tannin, and Mildew Stains

TimberTech products are formulated to inhibit mildew growth and minimize staining. Rinse off your TimberTech products periodically with a hose. Even if it appears clean, it is important to prevent build-up of pollen/debris. Mildew stains may occur where moisture, pollens, and/or dirt are present. Mildew needs a food source to grow, which can be grass, pollens, dirt, debris, wood and wood resins.

Cleaners that are recommended for use with TimberTech are:

- Sun Frog Composite Deck Cleaner (sunfrog.com)
- Super Deck Composite Deck Cleaner (superdeck.com)
- Corte Clean (corteclean.com)
- E Z Off Composite Wood Cleaner (sunbritesupply.com)
- Thompson's Water Seal—Oxy Action (thompsonswaterseal.com)

Spot Stains

Many stains can be cleaned with soap and water. If the stains have set, the following

cleaners have been found to remove or reduce the stains. Always follow the manufacturer's instructions to achieve maximum results. Areas cleaned may lighten; this will require 8-10 weeks exposure to the sun to match the remaining product.

Ornamental Rail, and BuilderRail:

General Cleaning:

- Soap & Water
- CorteClean

- Tree Sap:**
- Krud Kutter (krudkutter.com)
 - Simple Green (simplegreen.com)

- Spray Paint:**
- Lift Off #4 (liftoffinc.com)

- Oil, Grease:**
- Krud Cutter (krudcutter.com)
 - Oil Eater (oileater.com)

BBQ, Ketchup, Mustard, Jelly and Jam:

- Krud Cutter (krudcutter.com)

- Wine:**
- Wine Away (wineaway.com)

- Kool-Aid:**
- Oxi Clean (oxiclean.com)

RadianceRail & RadianceRail Express:

General Cleaning:

- Soap & Water
- CorteClean

Pencil marks or other scuffs:

- Mr. Clean Magic Eraser

RadianceRail & RadianceRail Express Touch-Up:

Duplicolor 2-in-1 Automobile Touch-up Paint is recommended for scratches, nicks and scuffs on TimberTech RadianceRail:

- For Coastal White use "Gloss White"
- For Classic Black use "Universal Flat Black"

ADA Compliant Hand Rail System

- Consult your local building codes for guard and handrail requirements.

TimberTech's ADA Hand Rail System conforms to the requirements of the American with Disabilities Act (ADA) - it provides a continuous gripping surface through its entire length. It is designed to be an aesthetically pleasing complement to TimberTech's Railing Systems and is easy to install.

Components Needed For Installing One ADA Hand Rail System:

- 1 104" Grab Rail with aluminum insert
1.5"OD x 104"
ADA104W
ADA104B
- 2 Aluminum Joiner Kit
1"OD x 6"
ADAJKT
- 3 4" x 4" 90° Inside/Outside Corner
1-1/2" OD x 4" x 4"
ADAOSCW
ADAOSCB
- 4 Inline Wall Mount Bracket
3"
ADAIWBW
ADAIWBB
- 5 Inside Corner 90° Standoff Bracket
6-1/4"
ADAINCW
ADAINCB
- 6 End Cap
1-1/2"
ADAECAPW
ADAECAPB
- 7 Handicap Loop
18" x 12" x 18"
ADAHDLW
ADAHDLB
- 8 Adjustable Internal Joiner
ADAADJ
- 9 90° Return Bracket
3.75" x 3.5"
ADA90RBW
ADA90RBB
- 10 External Swivel Connector
ADAEXTW
ADAEXTB
- 11 Standoff Bracket
2-1/4"
ADASOBW
ADASOBB

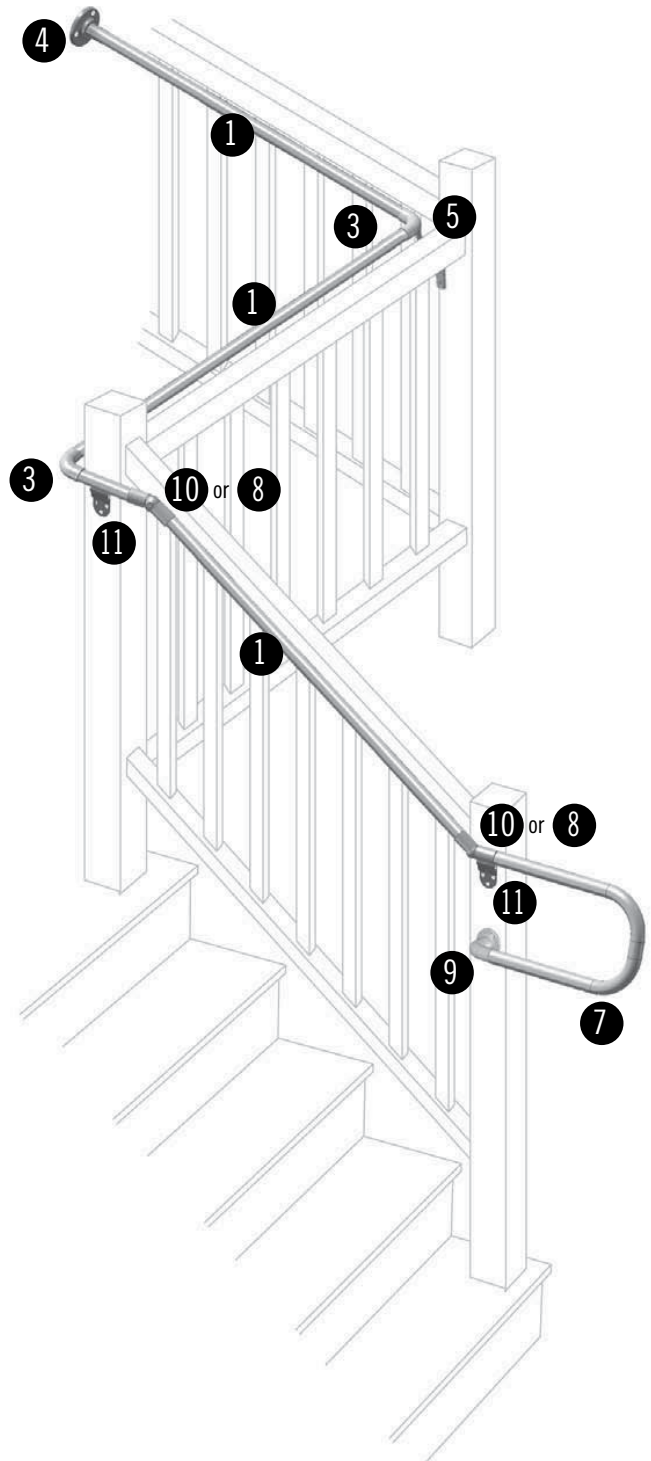

Handicap Loop

Used at the Bottom of Steps or Handicap Ramps

- Attach top bracket at desired location using appropriate connectors.
- Cut Handicap Loop to desired length.
- Connect Handicap Loop to ADA tube using the appropriate connector (Aluminum Joiner or Adjustable Internal Joiner.)
- Set Handicap Loop on top bracket, pre-drill with drill bit and install self-tapping screw provided.
- Install desired lower bracket.

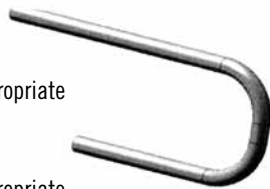

Adjustable Internal Joiner – 0 to 90°

Used for Angles

- Miter Cut ADA Grab Rail with aluminum insert to desired length.
- Install Adjustable Internal Joiner inside both ends of the tube.
- Pre-drill 90° Corner and Straight Joiner with drill bit, and install self tapping screw provided.



90° Return Bracket

Used for Both Post and Wall Returns

- Cut ADA Grab Rail tube with aluminum insert to desired length.
- Insert 90° bracket into the ADA tube.
- Install counter sunk screws provided through the bracket.
- Pre-drill aluminum reinforced tube and bracket with drill bit, and install self-tapping screw provided.



Inline Wall Mount

Used for Straight Wall Connections

- Cut ADA Grab Rail tube with aluminum insert to desired length.
- Insert 90° bracket into the ADA tube.
- Install counter sunk screws provided through the bracket.
- Pre-drill aluminum reinforced tube and bracket with drill bit, and install self-tapping screw provided.



Standoff Bracket

Used for Rail Applications on Walls or Posts

- Install counter sunk screws provided through the bracket into the mounting surface.
- Place rail at appropriate location on the bracket.
- Pre-drill aluminum reinforced ADA tube with drill bit, and install self-tapping screw provided.
- Place End Cap on rail.



Aluminum Joiner Kit

Used to Connect Two ADA Tubes or 90° Corner Brackets

- Cut ADA Grab Rail tube with aluminum insert to desired length.
- Pre-drill aluminum reinforced ADA tube and joiner with drill bit, and install self-tapping screw provided.

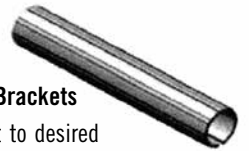

External Swivel Connector – 0 to 60°

Used for Step Angles

- Adjust External Swivel to desired angle and install set screw.
- Cut ADA Grab Rail Tube with aluminum insert to desired length.
- Insert External Swivel bracket into the ADA tube.
- Pre-drill aluminum-reinforced ADA Grab Rail Tube and bracket with drill bit, and install self-tapping screw provided.



Inside/Outside Corner – 90°

Used for Inside and Outside Corners

- Install two Straight Joiners into the 90° Corner.
- Pre-drill 90° Corner and Straight Joiner with drill bit and install self-tapping screw provided.
- Cut ADA Grab Rail tube with aluminum insert to desired length.
- Pre-drill aluminum reinforced tube and bracket with drill bit, and install self-tapping screw provided.



Inside Corner Standoff Bracket – 90°

Used with 90° Elbow for Inside Corner Applications

- Install counter sunk screws provided through the bracket into the mounting surface (corner of post.)
- Place 90° Corner at appropriate location on the bracket.
- Pre-drill 90° Corner with drill bit, and install self-tapping screw provided.



Secure-Mount Post System and Deck Mounting Kit

Visit www.timbertech.com/installation to view TimberTech installation videos.

TimberTech's Secure-Mount Post and Deck Mounting Kit provide a solution for installing railing posts directly onto a deck or porch surface, without the use of a 4x4 treated post. The Secure-Mount Post is designed for use on composite decks, concrete surfaces and commercial areas.

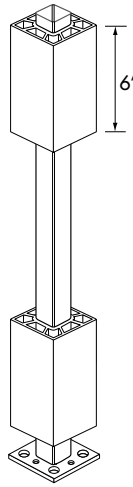

Secure Mount Post

Includes 2 Leveling Shims for deck or concrete applications.

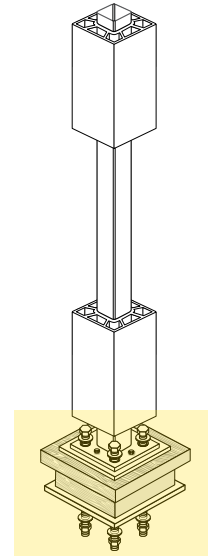

Deck Mounting Kit

Includes Leveling Plate, Base Plate and Flange Mounting Hardware.

Important Information

- It is the responsibility of the installer to meet all code and safety requirements and to obtain required building permits.
- Plumb post with level and shim between the deck and post-mount base plate with provided shims, if necessary.
- **For RadianceRail Applications: use the twelve #10 x 2" stainless steel screws that are included with the Secure Mount Post to replace the 3" green screws for the rail to post connection.**
- For mounting to concrete, additional mounting bolts must be purchased (See bottom of page 25.)

Flange Deck Mount Applications (hardware included)

- **36" x 6', 36" x 8' and 42" x 6' rail applications**
Install TimberTech Secure-Mount Post with optional TimberTech Flange Deck Mounting Kit that includes Leveling Plate, Base Plate, and Flange Mounting Hardware.
- **42" x 8' rail applications must use through bolt installation**
Use 3/8 Hex head bolt, carriage bolt or threaded rod a minimum of 13" in length must be mounted through the bottom post mount block and deck (as shown). Installer should determine the correct length of the bolt needed. Hardware for this application is not included.

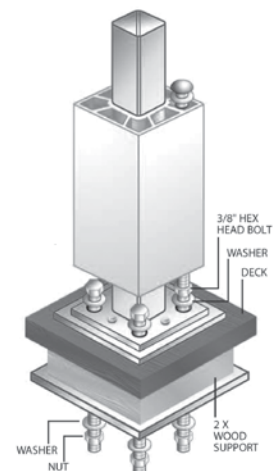

Composite Applications (hardware included)

The Deck Mounting Kit includes a Leveling Plate, Base Plate and Flange Mounting Hardware for composite applications.

- Whether you are installing a 36" or 42" high railing section, the Secure-Mount Post provides the flexibility for proper attachment with its adjustable Top Mounting Block.
- The Secure-Mount Post comes packaged and set for a 36" high railing application.
- To use with a 42" Railing System, remove the 1-1/4" Set screw, located inside the top opening of the Top Attachment Block.
- Through bolt pattern for 42" x 8' installation.

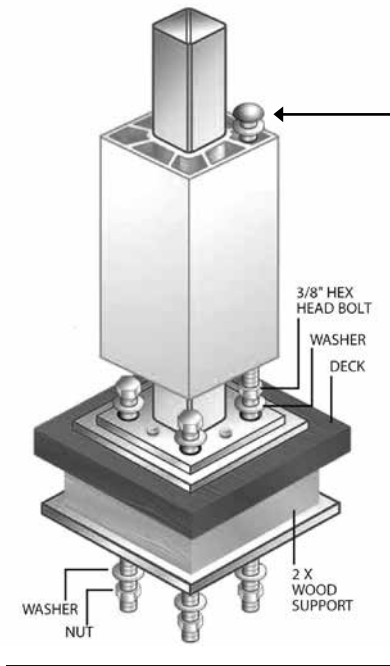

Once the set screw is removed, slide the Top Attachment Block up approximately 6" and align the bottom opening with the pre-drilled hole of the internal support post. Securely fasten the 1-1/4" set screw and you are ready for the 42" installation.

1 Determine Post Location

Placement of the Secure-Mount Post should be measured with a center-to-center measurement of 72" when installing a 6' rail section and 96" when installing an 8' rail section.

2 Install Blocking

Once you have determined the layout for the Secure-Mount Posts on the deck's substructure, you will need to install blocking between the designated joists.

A - Using a doubled 2x12 as the block, secure the block in the joist bay and attach on at least three sides.

- At least a #8 x 3" stainless steel or high-quality coated exterior wood screw for the block attachment is recommended and approved for use in treated lumber.
- Staggering 3" screws is recommended.

B - Note that the wood grain of the 2x12 block must be installed perpendicular to the outside rim joist of the deck.

- Installation of a perpendicular joist block will be needed to ensure attachment on all three sides of the blocking.

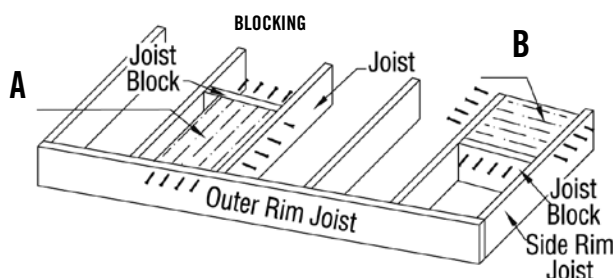

3 Attach Post

Once the TimberTech decking has been installed and the blocking is in place, use the base plate of the Secure-Mount Post as a template and mark the four corner holes for the 3/8" x 5-1/2" Hex Head Bolts.

- Drill four 7/16" holes through the marked holes, drilling through the deck plank and the reinforcement blocking below.
- Align the base plate over the drilled holes.
- Take the Secure-Mount Post and place it on the base plate lining up the holes.
- Screw the 5/16" leveling set screws into the four tapped holes.
- Insert the four 3/8" x 5-1/2" bolts into the drilled 7/16" holes.
- Take the bottom plate and line it up with the bolts under the TimberTech deck plank and the 2x12 support blocking.
- Install the washer and securely tighten with the included nut on all four 3/8" bolts.
- If needed, adjust the leveling set screws to plumb the Secure Mount Post.
- For corner post installations, use the off-set holes of the base plate.

Once the Secure-Mount Post is securely attached, trim the TimberTech Post Cover to the desired height and slide it over the post to begin rail section installation.

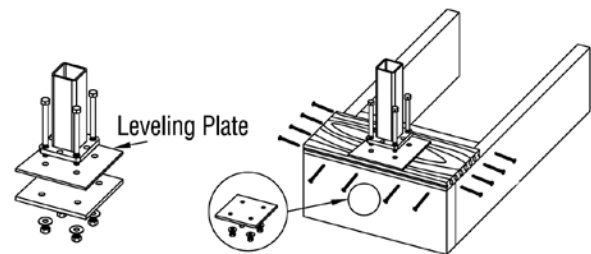

Concrete Mount Applications

(hardware NOT included)

- **36" x 6', 36" x 8' and 42" x 6' rail applications**
Install using Flange Mounted TimberTech Secure Mount Post.
- **42" x 8' rail applications**
Install through bolt (hardware NOT included).
- 3/8" Diameter Wedge Anchor recommended for concrete applications.
- Through bolt pattern for 42" x 8' installation.

Threaded rod would only be needed for 42" x 8' rail application and is not included. Threaded rod in a through bolt application on concrete would need to be used with an anchoring adhesive.

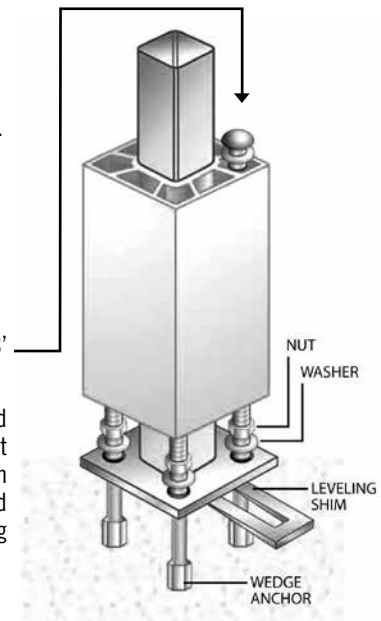

DeckLites Components

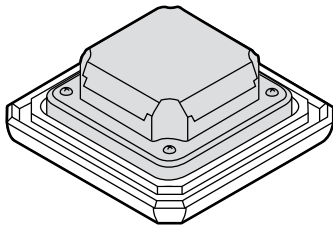

5 x 5 Post Lamp Module
RadianceRail

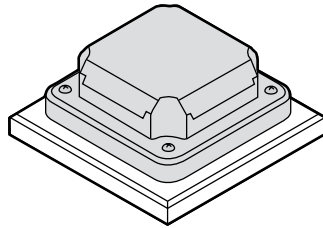

4 x 4 Post Lamp Module
Ornamental Rail, RadianceRail Express

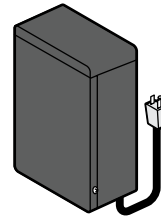

100W Transformer



Accent Light

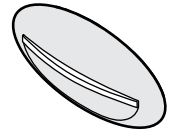

Stair Riser Light

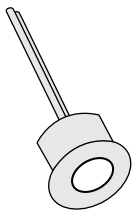

In-Deck Light

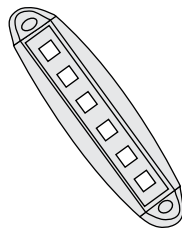

Under-Rail Light

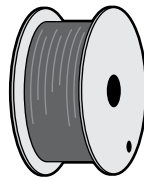

16/2 AWG Wire

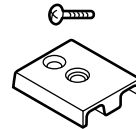

Cable Guide
& Screw
(12/bag)



Silicone Filled
Wire Nuts
(20/bag)

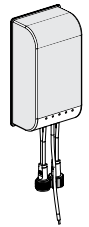

Dimmer*

Tools Required

In addition to a basic tool set, you will need the following for installation of DeckLites components.

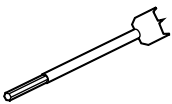

Spade Bits:
5/8"
3/4"
1"
1-1/2"



2.5mm
Allen Wrench

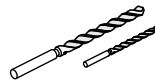

Drill Bits:
3/8"
7/64"
1/4"
3/16"

Important Safety Precautions

INSTRUCTIONS PERTAINING TO A RISK OF FIRE OR INJURY TO PERSONS IMPORTANT SAFETY INSTRUCTIONS

WARNING – To reduce the risk of FIRE OR INJURY TO PERSONS:

Turn off/unplug before servicing fixtures. Contact only switch/plug when turning on.

Keep lamp away from materials that may burn.

Do not operate the luminaire fitting with a missing or damaged cover.

SAVE THESE INSTRUCTIONS

For information about DeckLites® LED visit www.timbertech.com/DeckLites.

*For installation instructions for the dimmer, visit <http://www.timbertech.com/installation/installation-resources>

TimberTech DeckLites LED Layout Overview

The TimberTech DeckLites LED system is designed for use with the RadianceRail, RadianceRail Express and Ornamental Rail products.

Below is a sample lighting layout showing fixture placement and wiring routes. When laying out the wiring for your deck, keep the following in mind:

- Building codes vary by locale, please consult all applicable codes before beginning project.
- Modifications must be made to railing components during assembly to accommodate wiring and fixtures. Do not begin deck construction until you have read the lighting instructions.
- This unit secondary wiring shall be protected by routing in close proximity to the luminaire or fitting, or next to a building structure such as a house or deck. The wiring shall not be buried except for a maximum 6 inches (15.2cm) in order to connect to the main secondary wire.
- A maximum of 40W can be applied to a single circuit. The maximum recommended load for the transformer is 90 watts. Please refer to chart below to determine that wattage of each fixture.
- The 16AWG secondary supply wire can be buried to a maximum of 6" for routing under deck or other obstacles. The Luminary (unit secondary) wires cannot be buried underground.
- Luminaries shall not be installed within 10 feet (1.52m) of a pool, spa or fountain.
- Trim post covers to correct length - see Post and Rail Prep page.

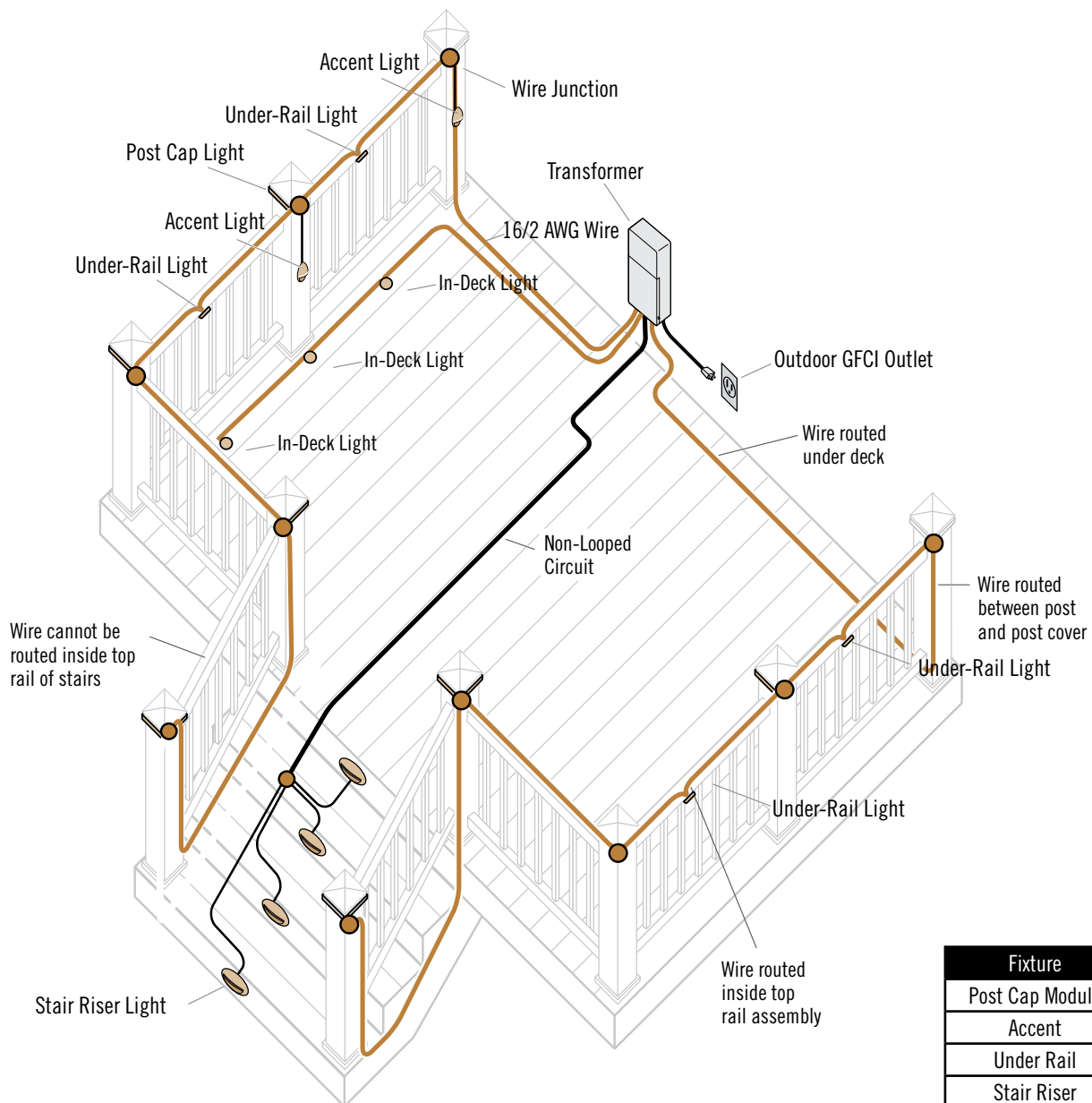

Fixture	Wattage
Post Cap Module	3.0W
Accent	1.6W
Under Rail	1.5W
Stair Riser	1.3W
In-Deck	.5W

Wiring Instructions

Wire Connections

Connections between the main 16/2AWG cable and the lighting fixtures are made using the space between the post and the Post Cap or Post Light Module as a junction box.

When routing the main wire around the deck, leave a loop of extra wire at the top of each post to allow for splicing connections.

Use silicone filled wire nuts with corrosion protection and intended for outdoor use to make all connections. They shall be copper, copper alloy, or the equivalent.



Be sure to **MAINTAIN POLARITY** by aligning ridges when splicing the main 16/2AWG wires or shorting will occur. Polarity for the 18AWG fixture wires is not critical.

When making splices, **do not pre-twist wires**. Pre-twisting wires can lead to a poor seal inside the wire nut causing corrosion and/or voltage drop.

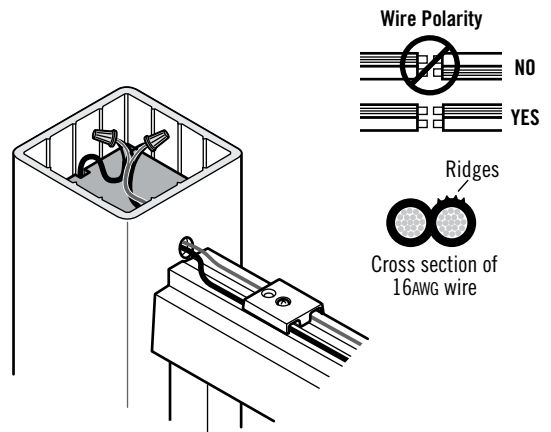

Wire Nut Instructions

Use the following guidelines for correct usage of wire nuts.

IMPORTANT: Turn off power before installing or removing connector. Product to be used in accordance with local and national codes.

1. Strip wires 5/8"
2. Align frayed strands of conductors.
3. Do not pre-twist. Place stripped wires together with ends even, but lead smaller stranded wires slightly ahead of larger solid or stranded wire.
4. Twist connector onto wires pushing firmly until hand-tight. **DO NOT** over torque.
5. Wipe excess sealant in and around conductors. **DO NOT REUSE**.

Transformer Connections

Consult the instructions provided with the transformer for additional information.

Power is supplied to the lighting fixtures via 16/2AWG wires connected to the provided transformer. One side of the 16/2AWG wire is connected to the Common terminal (C), the other side is connected to an Output terminal. One side of the 16/2AWG wire contains raised ridges to allow for easy identification (see Wire Connections section). The maximum recommended load for the transformers is 90 watts.

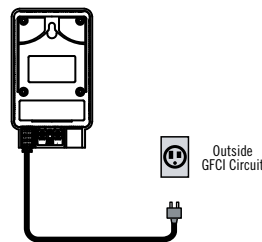

Transformer Settings

100 Watt Transformer	
On	Turns unit on
Off	Turns unit off
Auto	Photocell Control "Auto" – Lights come on at dusk and go off at dawn
4H	Stays on 4 hours after dusk
6H	Stays on 6 hours after dusk
8H	Stays on 8 hours after dusk

Dimmer Instructions

Install the Dimmer next to the DeckLites LED Transformer. Use the provided 10" wire and water-tight connector to connect the Dimmer to the DeckLites LED Transformer. Next, use the provided 10' wire and water-tight connector to connect the Dimmer to main run of wire.

To use the Dimmer, turn the DeckLites LED Transformer to a setting that turns the DeckLites on when desired. To dim the lights, press the button on the remote or on the dimmer until the desired brightness is achieved.

The recommended load for the dimmer is between 20-90 watts.

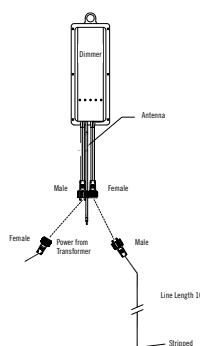

Post & Rail Preparation

5 x 5: RadianceRail

Post & Post Covers

(The following instructions are for a rail height of 36")

- 1 Trim 4x4 wood posts to 35-1/2" above deck surface.
- 2 Trim Post Covers to length: 38" for a lit post
40-1/8" for an unlit post

For best results, use a miter saw with a fine toothed blade to make Post Cover cuts. Check cuts for square.

- 3 Feed main 16/2AWG cable between post and Post Covers. (See *Wire Connections* section for more info.)

Run wires up corner voids created by Post Cover Ribs.

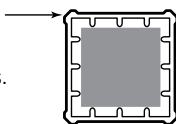

Railing

- 1 Install Support Rails and Balusters as normal, DO NOT install Top Rail yet.

- 2 Drill a 5/8" hole through the Post Cover on centerline, directly above rail Mounting Blocks.

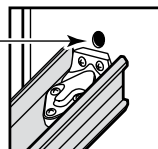

- 3 After running all wiring, secure four Cable Guides to Support Rail using #8 x 3/4" screws. Use the Cable Guides to pre-drill holes thru the Support Rail with a 3/16" bit.

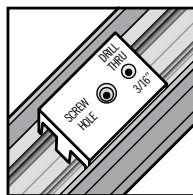

Cable Guide Placement

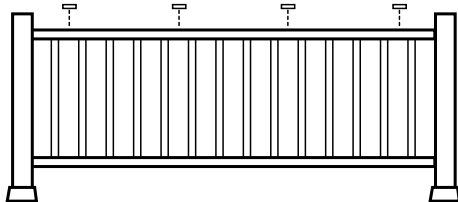

- 4 Make a notch on the centerline of the Top Rail by boring a 3/4" hole centered 1/2" back from the end of the rail, then cut it out to form an open slot.

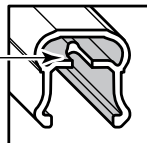

- 5 Attach Top Rails before installation of Post Cap Lights. Use the holes that were pre-drilled through the Cable Guides to attach the Top Rail. FAILURE TO USE THESE HOLES MAY RESULT IN WIRE DAMAGE.

4 x 4: Ornamental Rail, RadianceRail Express

Post & Post Covers

(The following instructions are for a rail height of 36")

- 1 Trim 4x4 wood posts to 34-1/2" above deck surface.
- 2 In order to provide clearance for wiring between the post and Post Cover you must create a wire channel.

Rout a 1/4" by 1/4" slot down the post

OR

Chamfer the corner of the post

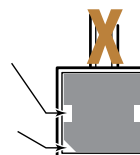

NOTE: Do not rout a wire channel where a rail is to be mounted.

- 3 If you plan to install a post mounted Accent Light, you must rout a slot down the post to the desired fixture position. (See *Accent Light* instructions.)

- 4 Trim Post Covers to length: 36-7/8" for a lit post
39" for an unlit post.

For best results, use a miter saw with a fine toothed blade to make Post Cover cuts. Check cuts for square.

- 5 Feed main 16/2AWG cable up or down post using prepared feature. (See *Wire Connections* section for more information)

Railing (Only for Ornamental Rail)

- 1 Install Universal Rails and Balusters as normal, DO NOT install Top Rail yet.

- 2 Drill a 5/8" hole through the Post Cover on centerline, directly above the Universal Rail.

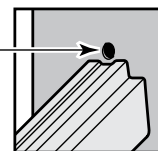

- 3 After running all wiring, secure four Cable Guides to Universal Rail using #8 x 3/4" screws. Position every 4th Baluster, avoiding Balusters and Baluster Mounting Blocks if installed. Use the Cable Guides to pre-drill holes thru the Universal Rail with a 3/16" bit.

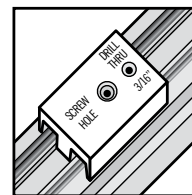

- 4 Make a notch on the centerline of the Top Rail by boring a 3/4" hole centered 1/2" back from the end of the rail, then cut it out to form an open slot.

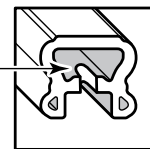

- 5 Attach Top Rails before installation of Post Cap Lights. Use the holes that were pre-drilled through the Cable Guides to attach the Top Rail. FAILURE TO USE THESE HOLES MAY RESULT IN WIRE DAMAGE.

Installing Post Cap Light

Post Lamps must be installed after the rail assembly has been completed.

! Before installing, refer to Post & Rail Preparation section.

- 1 Install the Lens onto the Post Cover as shown.
- 2 Remove the Post Lamp Cover from the Post Lamp Bottom Housing.
- 3 Trim excess wire length and make wiring connections to 16/2AWG main cable and other 18/2AWG luminary wires. **Check to confirm polarity of main cable connections.**
- 4 Coil the connected wires inside the Post Cover and insert the Post Lamp Bottom Housing into the Lens. Check to make sure no wires are exposed or pinched between Lens and Bottom Housing.

- 5 Install the mounting screws and washers assembled as shown. **Watch as screws are installed to ensure that wires are clear of screw tip prior to driving them into the wood post. Tighten only until the silicone washer begins to compress. Over-tightening could break the Bottom Housing causing permanent damage.**

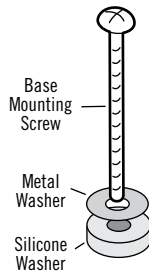

- 6 Reinstall Post Lamp Cover and screws.
- 7a For 5x5: Install Cap Spring into Post Cap as shown (place finger and thumb on Cap Spring tabs, flex gently until Cap Spring appears slightly bowed, insert Cap Spring into Post Cap approximately at the center of the opening until bowed back ends contact the inside top of the Post Cap then relax finger and thumb pressure). Press Cap Spring into seated position as shown.
- 7b For 4x4 (Includes Gasket): Set gasket centered on post lamp cover.
- 8 Install Post Cap onto Post Lamp Cover.

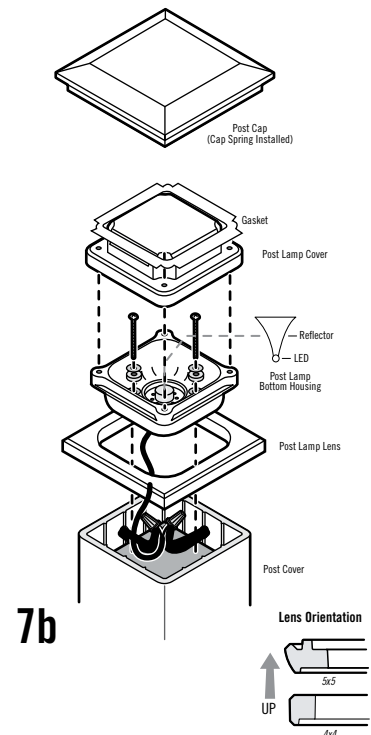
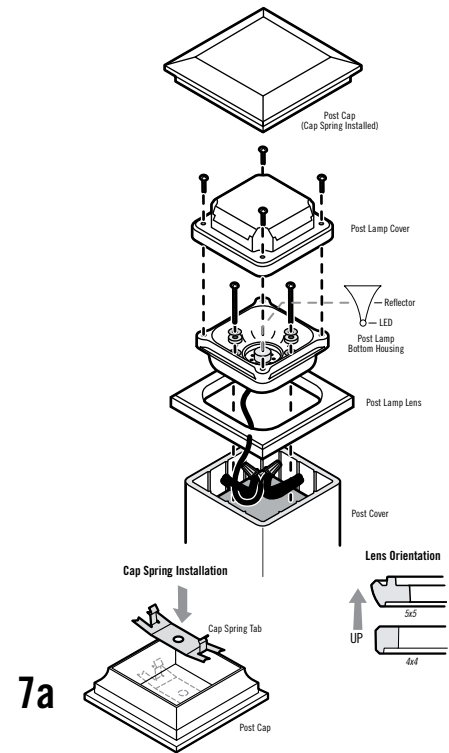

Installing Post Mounted Accent Light

- 1 Accent Light wire channel must be routed during the installation of the Post Cover. The Post Cover and the wood post must be prepared in advance to accommodate installation of the Accent Light. (No post preparation is necessary for RadianceRail.)
- ⚠ If using **Ornamental Rail, RadianceRail Express or BuilderRail**, prepare the wood post by routing a 1/4" wide by 1/4" deep wire channel up the center of the post on the face where the Accent Light will be mounted. For main cable, slightly bevel the corner of the 4x4 post.
- 2 If a **Post Skirt** is used, install it over the wood post before installing the **Post Cover**. You will not be able to install Post Skirt after Post Cover and Accent Light are in place.
- 3 Remove Accent Light Cover from Accent Light Back Plate by loosening Set Screw located at bottom of Accent Light Cover.
- 4 Prepare the Post Cover in the following manner:
 - Cut the Post Cover to the desired length.
 - Determine the height the Accent Light will be mounted.
 - Mark the location of the wire hole and the mounting screw holes using the Accent Light Back Plate.
 - Drill a 3/8" hole for the wire and drill two 7/64" holes for the mounting screws.
- 5 Route the Accent Light wire through the BackPlate then through the wire hole in the Post Cover then invert the Post Cover and allow the wire to extend out the top end of the Post Cover.
- 6 Hold the Accent Light Back Plate loosely in position and slide the Post Cover over the wood post and into the Post Skirt. Make sure the wire is in the routed wire channel.
- 7 Attach the Accent Light Back Plate to the post using two #8 x 3/4" screws provided.
- 8 Re-install Accent Light Cover and secure with Set Screw with Allen Wrench.
- 9 Trim excess wire and make wiring connections. (See *Connections* section of manual).

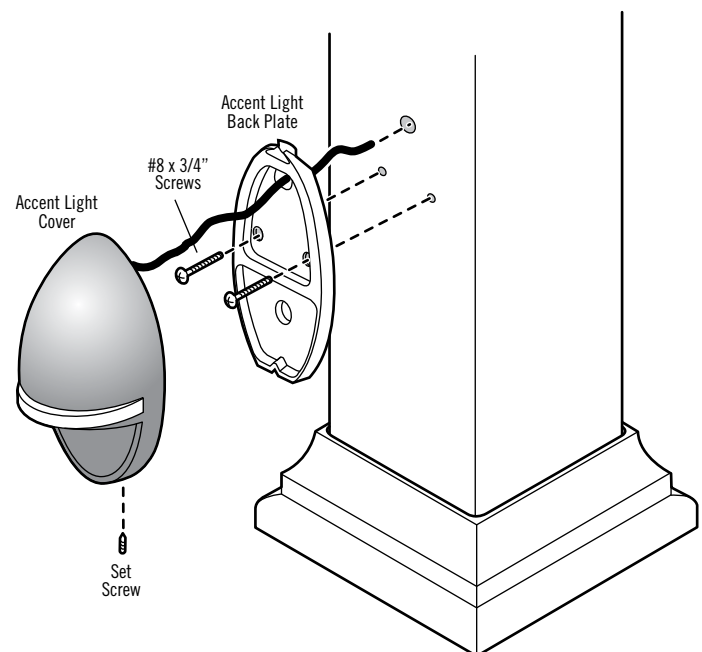
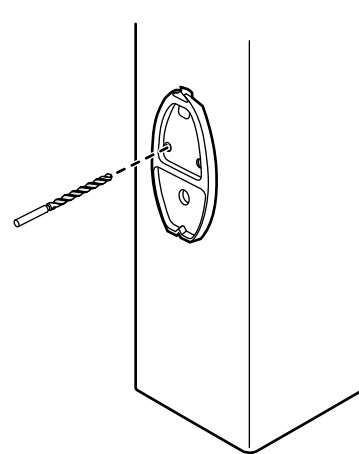
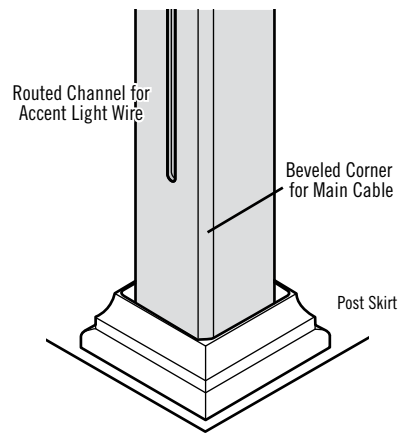

Installing Stair Riser Light

- 1 Locate and mark vertical and horizontal centerlines for Stair Riser Light location. Level the back plate and secure using #6 x 1" wood screws.
- 2 Use the back plate as a template to locate the center of the 1-1/2" hole for the "bump out".
- 3 Cut a 1-1/2" diameter hole at the center point using a 1-1/2" spade bit.
- 4 Trim excess wire length and make wire connection to main circuit wire using wire nuts provided.
- 5 Align the lighting "bump out" with the 1-1/2" hole and assure alignment between the Stair Riser light and the back plate.
- 6 Secure housing to back plate using the set screw with a 2.5mm Allen wrench.

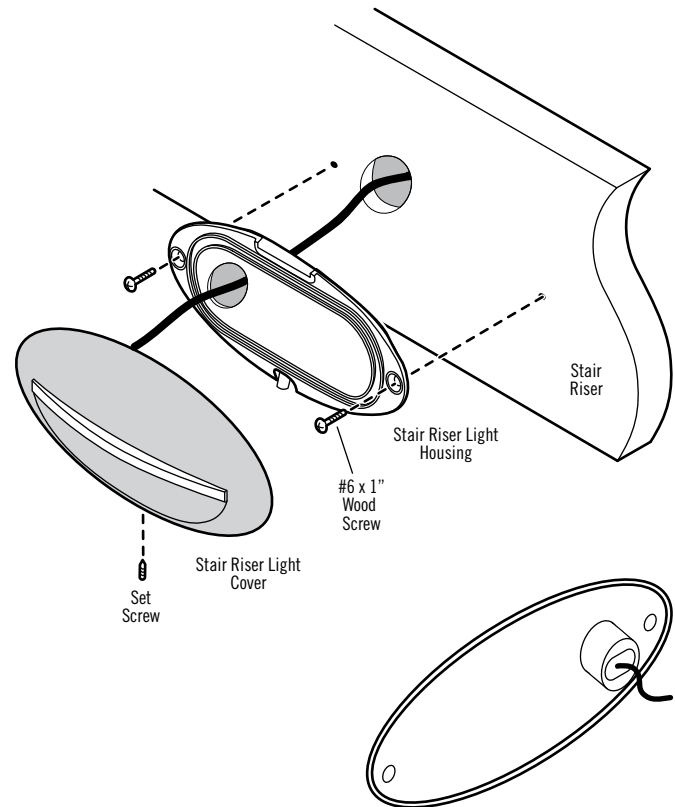

Installing Under-Rail Light

- 1 Choose the location for the Under-Rail Light so it is centered in the balusters.
- 2 Drill a 3/8" hole to feed the wire through the H Channel.
- 3 Feed the wire and mount the light to the recessed H Channel making sure the light is tilted in (light comes with a 15° tilt which is usually facing the deck). Use the center alignment beam for a guide for the 2 screws. Use 8-3/4" screw size.
- 4 Trim excess wire length and make wire connection to main circuit wire using nuts provided.

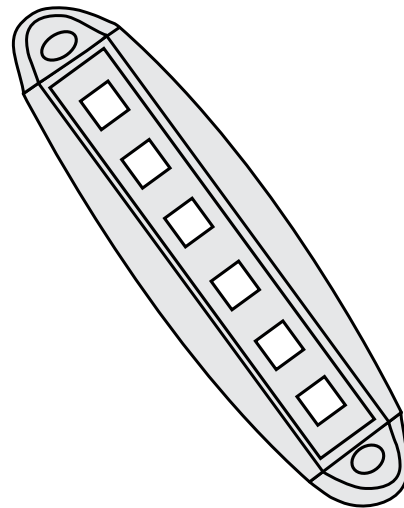

Installing In-Deck Light

- ⚠** *In-deck light should be installed in a low foot-traffic area.
In-deck light can only be used when there is room under the deck to access the wires to make all of the connections*

- 1 Locate and mark the centerline of the deck plank where the in-deck light will be mounted.
- 2 On the desired point of the center line, use a 1" spade bit to create a through hole (be sure not to drill into the substructure.)

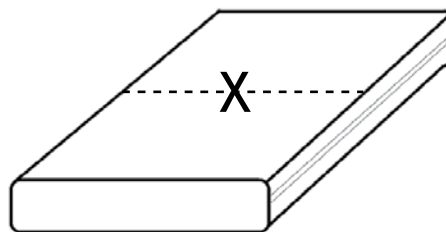

- 3 Guide the light's wire into the through hole.

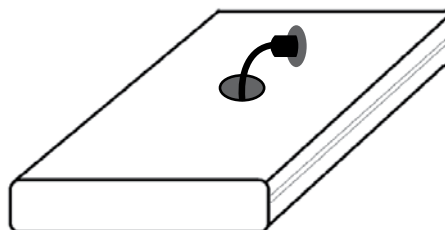

- 4 Push the lighting fixture into the through hole until the flange touches the deck surface.

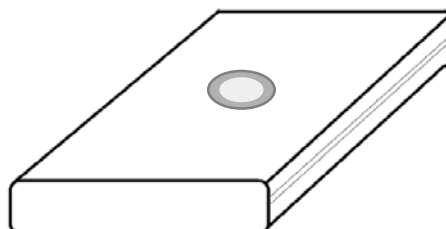

- 5 The wire connections can then be made under the deck's surface.

25-Year Limited Residential Warranty 10-Year Limited Commercial Warranty



Alternative decking materials, rail systems, accessories and the DrySpace deck drainage system

Statement of Warranty: This warranty is given to the original purchaser, residential or commercial as the case may be ("Purchaser"), of TimberTech alternative decking materials, rail systems (excluding all metal baluster components of such rail systems and DeckLites, which are covered under separate warranties), and accessories (individually and collectively "Decking Materials") and the DrySpace deck drainage system ("DrySpace" and, collectively with the Decking Materials, the "TimberTech Products"). This warranty does not extend to fasteners that are not supplied by TimberTech. For purposes of this warranty, a residential Purchaser shall refer to a single-family residential homeowner and a commercial Purchaser shall refer to any Purchaser other than a single-family residential homeowner.

TimberTech Limited ("TimberTech") warrants to Purchaser that, for a period of twenty-five (25) years (Residential) & ten (10) years (Commercial) from the date of the original purchase, residential or commercial as the case may be, (the "Term"), under normal use and service conditions, that: (1) the Decking Materials will be free from material defects in workmanship and materials, and will not check, split, splinter, rot or suffer structural damage from termites or fungal decay; and (2) DrySpace will not peel, blister, pit, flake, crack or corrode as a result of manufacturing defects, or as a result of exposure to ocean air (salt spray).

All warranties are subject to the exclusions, limitations and restrictions set forth below.

Obtaining Warranty Performance: If Purchaser discovers a defect in the TimberTech Products during the Term, Purchaser must, within thirty (30) days from the discovery of the alleged defect but no later than the end of the Term, notify TimberTech in writing, at the following address:

TimberTech Limited
894 Prairie Avenue
Wilmington, Ohio 45177
Attn: Claims Department

Purchaser must include in this notification proof of purchase and a statement explaining the defect. TimberTech may request additional information. After reviewing all information, TimberTech will make a determination regarding the validity of such claim. If TimberTech determines that Purchaser's claim is valid, TimberTech will, at its option, either replace the defective TimberTech Products or refund the portion of the purchase price paid by Purchaser for such defective TimberTech Products (not including the cost of its initial installation).

If a residential Purchaser makes a valid warranty claim hereunder during years eleven (11) through twenty-five (25) after the original purchase, then the residential Purchaser's recovery will be prorated as indicated below. If TimberTech is providing replacement materials, it may elect to replace the percentage listed below of boards otherwise meeting the requirements for a claim; if TimberTech is refunding the purchase price, it may elect to refund the percentage listed below of the purchase price of boards otherwise meeting the requirements for a claim.

Year of Claim	Recovery
11	80%
12	80%
13	80%
14	60%
15	60%

Year of Claim	Recovery
16	60%
17	40%
18	40%
19	40%
20	20%

Year of Claim	Recovery
21	20%
22	20%
23	10%
24	10%
25	10%

This warranty shall not cover, and TimberTech shall not be responsible for, costs and expenses incurred with respect to the removal of the defective TimberTech Products or the installation of replacement materials, including but not limited to, labor and freight. The foregoing remedies are the SOLE AND EXCLUSIVE REMEDY FOR BREACH OF ANY WARRANTY.

Transfer of Warranty: This warranty may be transferred one (1) time, within the five (5) year period beginning from the date of original purchase by Purchaser, to a subsequent buyer of the property upon which the TimberTech Products were originally installed.

Exclusions from Warranty Coverage: TimberTech does not warrant against and is not responsible for, and no implied warranty shall be deemed to cover, any product failure, product malfunction, or damages attributable to: (1) improper installation of the TimberTech Products and/or failure to abide by TimberTech's installation guidelines, including but not limited to improper gapping; (2) use of TimberTech Products beyond normal use, or in an application not recommended by the TimberTech installation guidelines and local building codes; (3) movement, distortion, collapse or settling of the ground or the supporting structure on which the TimberTech Products are installed; (4) any act of God (such as flooding, hurricane, earthquake, lightning, etc.), environmental condition (such as air pollution, mold, mildew, etc.), or staining from foreign substances (such as dirt, grease, oil, etc.); (5) variations or changes in color of TimberTech Products; (6) normal weathering due to exposure to sunlight, weather and atmosphere which can cause colored surfaces to, among other things, flake, chalk, or accumulate dirt or stains; (7) improper handling, storage, abuse or neglect of the TimberTech Products by Purchaser, the transferee or third parties; (8) any fasteners not supplied by TimberTech; or (9) minor dripping from DrySpace.

Purchaser is solely responsible for determining the effectiveness, fitness, suitability and safety of the TimberTech Products in connection with their use in any particular application.

Limitations: DISCLAIMER OF WARRANTIES: EXCEPT FOR (1) THE EXPRESS WRITTEN WARRANTY CONTAINED HEREIN, AND, (2) THE 25 YEAR LIMITED RESIDENTIAL FADE AND STAIN WARRANTY APPLICABLE TO EARTHWOOD EVOLUTIONS DECKING ONLY (WHICH IS IN ADDITION TO THE WARRANTY CONTAINED HEREIN), TIMBERTECH MAKES NO OTHER WARRANTIES, GUARANTEES OR INDEMNITIES, WHETHER EXPRESS OR IMPLIED, ARISING BY LAW, COURSE OF DEALING, USAGE OF TRADE, CUSTOM OR OTHERWISE, INCLUDING BUT NOT LIMITED TO THE IMPLIED WARRANTY OF MERCHANTABILITY AND IMPLIED WARRANTY OF FITNESS FOR A PARTICULAR PURPOSE, AND ALL SUCH OTHER WARRANTIES, GUARANTEES AND INDEMNITIES ARE HEREBY DISCLAIMED, OVERRIDDEN AND EXCLUDED FROM THIS TRANSACTION FOR THE WARRANTY TERM AND BEYOND THE WARRANTY TERM.

Some states do not allow limitations on how long an implied warranty lasts so the above limitation may not apply to you.

LIMITATION OF REMEDIES AND EXCLUSION OF CONSEQUENTIAL AND INCIDENTAL DAMAGES: TIMBERTECH'S LIABILITIES ARE LIMITED SOLELY AND EXCLUSIVELY TO THE OBLIGATIONS SPECIFICALLY UNDERTAKEN HEREIN, AND UNDER NO CIRCUMSTANCES WILL TIMBERTECH BE LIABLE OR OBLIGATED FOR ANY INCIDENTAL, CONSEQUENTIAL, INDIRECT, SPECIAL, PUNITIVE OR ANY OTHER DAMAGES OF ANY KIND WHATSOEVER (INCLUDING, BUT NOT LIMITED TO, LOST PROFITS, LOST SALES, LOSS OF GOODWILL, USE OF MONEY, USE OF GOODS, STOPPAGE OF WORK, OR IMPAIRMENT OF ASSETS), WHETHER FORESEEABLE OR UNFORESEEABLE, ARISING OUT OF BREACH OR FAILURE OF EXPRESS OR IMPLIED WARRANTY, BREACH OF CONTRACT, FRAUD, MISREPRESENTATION, NEGLIGENCE, STRICT LIABILITY IN TORT OR OTHERWISE, EXCEPT AND ONLY TO THE EXTENT THIS LIMITATION IS SPECIFICALLY PRECLUDED BY APPLICABLE LAW OF MANDATORY APPLICATION. TIMBERTECH'S LIABILITY WITH RESPECT TO DEFECTIVE PRODUCTS SHALL IN NO EVENT EXCEED THE REPLACEMENT OF SUCH PRODUCTS OR REFUND OF THE PURCHASE PRICE, AS DESCRIBED ABOVE.

Some states do not allow the exclusion or limitation of incidental or consequential damages, so the above limitation or exclusion may not apply to you. This warranty gives you specific legal rights, and you may also have other rights that vary from state to state.

Miscellaneous: This writing is understood and intended to be the final expression of the parties' agreement and is a complete and exclusive statement of the terms and conditions with respect thereto, superseding all prior agreements or representations, oral or written, and all other communication between the parties relating to the subject matter of this agreement. This warranty may not be altered or amended except in a written instrument signed by TimberTech and Purchaser or permitted transferee. No agent, employee or any other party is authorized to make any warranty in addition to that made in this agreement and TimberTech shall not be bound by any such statements other than those contained in this warranty.

This warranty shall only be applicable and enforceable in the United States of America.

This warranty is effective for purchases (residential or commercial, as the case may be) made on or after January 1, 2011.

Copyright (c) 2012 TimberTech.

5-Year Limited DeckLites Warranty

Statement of Warranty: This warranty is given to the original purchaser, residential or commercial, ("Purchaser") of TimberTech DeckLites LED products ("DeckLites"). This warranty does not extend to fasteners that are not supplied by TimberTech.

TimberTech Limited ("TimberTech") warrants to Purchaser that for a period of five (5) years from the date of original consumer purchase (the "Term"), under normal use and service conditions, DeckLites will be free from defects in material and workmanship, and will not crack, peel, blister or corrode as a result of manufacturing defects.

All warranties are subject to the exclusions, limitations and restrictions set forth below.

Obtaining Warranty Performance: If Purchaser discovers a defect in the TimberTech Products during the Term, Purchaser must, within thirty (30) days from the discovery of the alleged defect but **no later than the end of the Term**, notify TimberTech in writing, at the following address:

TimberTech Limited • 894 Prairie Avenue • Wilmington, Ohio 45177 • Attn: Claims Department

Purchaser must include in this notification proof of purchase and a statement explaining the defect. TimberTech may request additional information. After reviewing all information, TimberTech will make a determination regarding the validity of such claim. If TimberTech determines that Purchaser's claim is valid, TimberTech will, at its option, either replace the defective TimberTech Products or refund the portion of the purchase price paid by Purchaser for such defective TimberTech Products (not including the cost of its initial installation). This warranty shall not cover, and TimberTech shall not be responsible for, costs and expenses incurred with respect to the removal of the defective TimberTech Products or the installation of replacement materials, including but not limited to, labor and freight. The foregoing remedies are the **SOLE AND EXCLUSIVE REMEDY FOR BREACH OF ANY WARRANTY**.

Transfer of Warranty: This warranty may be transferred one (1) time within the Term to a subsequent buyer of the property upon which DeckLites were originally installed. Transfer of this warranty does not extend the Term of the warranty.

Exclusions from Warranty Coverage: TimberTech does not warrant against and is not responsible for, and no implied warranty shall be deemed to cover, any damage or loss attributable to: (1) improper installation of DeckLites and/or failure to abide by TimberTech's installation guidelines; (2) use of DeckLites in an application not recommended by the TimberTech installation guidelines (including, but not limited to, immersion or submersion of the products in water) and local building codes; (3) any act of God (such as flooding, hurricane, earthquake, lightning (or other incidences of excessive voltage), natural disaster, etc.), environmental condition (such as air pollution, mold, mildew, etc.), or staining from foreign substances (such as dirt, grease, oil, etc.); (4) variations or changes in color of DeckLites; (5) normal weathering due to exposure to sunlight, weather and atmosphere which can cause colored surfaces to, among other things, flake, chalk, or accumulate dirt or stains; (6) improper handling, storage, abuse or neglect of DeckLites by Purchaser, the transferee or third parties; (7) use in harsh industrial or marine environments; or (8) any fasteners not supplied by TimberTech.

Purchaser is solely responsible for determining the effectiveness, fitness, suitability and safety of DeckLites in connection with their use in any particular application.

Limitations: DISCLAIMER OF WARRANTIES: EXCEPT FOR THE EXPRESS WRITTEN WARRANTY CONTAINED HEREIN, TIMBERTECH MAKES NO OTHER WARRANTIES, GUARANTEES OR INDEMNITIES, WHETHER EXPRESS OR IMPLIED, ARISING BY LAW, COURSE OF DEALING, USAGE OF TRADE, CUSTOM OR OTHERWISE, INCLUDING BUT NOT LIMITED TO THE IMPLIED WARRANTY OF MERCHANTABILITY AND IMPLIED WARRANTY OF FITNESS FOR A PARTICULAR PURPOSE, AND ALL SUCH OTHER WARRANTIES, GUARANTEES AND INDEMNITIES ARE HEREBY DISCLAIMED, OVERRIDDEN AND EXCLUDED FROM THIS TRANSACTION.

Some states do not allow limitations on how long an implied warranty lasts so the above limitation may not apply to you.

LIMITATION OF REMEDIES AND EXCLUSION OF CONSEQUENTIAL AND INCIDENTAL DAMAGES: TIMBERTECH'S LIABILITIES ARE LIMITED SOLELY AND EXCLUSIVELY TO THE OBLIGATIONS SPECIFICALLY UNDERTAKEN HEREIN, **AND UNDER NO CIRCUMSTANCES WILL TIMBERTECH BE LIABLE OR OBLIGATED FOR ANY INCIDENTAL, CONSEQUENTIAL, INDIRECT, SPECIAL, PUNITIVE OR ANY OTHER DAMAGES OF ANY KIND WHATSOEVER** (INCLUDING, BUT NOT LIMITED TO, LOST PROFITS, LOST SALES, LOSS OF GOODWILL, USE OF MONEY, USE OF GOODS, STOPPAGE OF WORK, OR IMPAIRMENT OF ASSETS), WHETHER FORESEEABLE OR UNFORESEEABLE, ARISING OUT OF BREACH OR FAILURE OF EXPRESS OR IMPLIED WARRANTY, BREACH OF CONTRACT, FRAUD, MISREPRESENTATION, NEGLIGENCE, STRICT LIABILITY IN TORT OR OTHERWISE, EXCEPT AND ONLY TO THE EXTENT THIS LIMITATION IS SPECIFICALLY PRECLUDED BY APPLICABLE LAW OF MANDATORY APPLICATION. TIMBERTECH'S LIABILITY WITH RESPECT TO DEFECTIVE PRODUCTS SHALL IN NO EVENT EXCEED THE REPLACEMENT OF SUCH PRODUCTS OR REFUND OF THE PURCHASE PRICE, AS DESCRIBED ABOVE.

Some states do not allow the exclusion or limitation of incidental or consequential damages, so the above limitation or exclusion may not apply to you. This warranty gives you specific legal rights, and you may also have other rights that vary from state to state.

Miscellaneous: This writing is understood and intended to be the final expression of the parties' agreement and is a complete and exclusive statement of the terms and conditions with respect thereto, superseding all prior agreements or representations, oral or written, and all other communication between the parties relating to the subject matter of this agreement. This warranty may not be altered or amended except in a written instrument signed by TimberTech and Purchaser or permitted transferee. No agent, employee or any other party is authorized to make any warranty in addition to that made in this agreement and TimberTech shall not be bound by any such statements other than those contained in this warranty.

This warranty shall only be applicable and enforceable in the United States of America.

This warranty is effective for consumer purchases made on or after January 1, 2009.

Copyright (c) 2009 TimberTech.

25-Year Limited Warranty for Metal Baluster Components of Rail Systems with Metal Balusters

Statement of Warranty

This warranty is given to the original consumer purchaser ("Purchaser"), of TimberTech Limited ("TimberTech") rail systems utilizing metal balusters. TimberTech warrants to Purchaser that, for a period of twenty-five (25) years from the date of the original consumer purchase (the "Term"), that the metal baluster components of TimberTech's rail systems utilizing metal balusters ("Metal Balusters") will be free from defects in material and workmanship, including cracking, peeling, blistering of the finish and extensive corrosion (rusting). For purposes of this warranty, corrosion (rusting) is deemed extensive when there are multiple rust-through perforation instances on the same piece of product.

All warranties are subject to the exclusions, limitations and restrictions set forth below.

Obtaining Warranty Performance

If Purchaser discovers a defect during the Term, Purchaser must, within thirty (30) days from the discovery of the alleged defect but no later than the end of the Term, notify TimberTech in writing, at the following address:

TimberTech Limited
894 Prairie Avenue
Wilmington, Ohio 45177
Attn: Claims Department

Purchaser must include in this notification proof of purchase and a statement explaining the defect. TimberTech may request additional information. After reviewing all information, TimberTech will make a determination regarding the validity of such claim. If TimberTech determines that Purchaser's claim is valid, TimberTech will, at its option, either replace the defective part or refund the portion of the purchase price paid by Purchaser for such defective part (not including the cost of its initial installation) according to the proration schedule set forth below. This warranty shall not cover, and TimberTech shall not be responsible for, costs and expenses incurred with respect to the removal of the defective Metal Balusters or the installation of replacement materials, including but not limited to, labor and freight, as well as shipping charges and sales tax. The foregoing remedies are the **SOLE AND EXCLUSIVE REMEDY FOR BREACH OF ANY WARRANTY**.

If Purchaser makes a valid warranty claim hereunder during years eleven (11) through twenty-five (25) after the original consumer purchase, then Purchaser's recovery will be prorated as indicated below. If TimberTech is providing replacement materials, it may elect to replace the percentage listed below of Metal Balusters otherwise meeting the requirements for a claim; if TimberTech is refunding the purchase price, it may elect to refund the percentage listed below of the purchase price of Metal Balusters otherwise meeting the requirements for a claim.

1 – 10 years	100% replacement/refund
11 – 20 years	75% replacement/refund
21 – 25 years	50% replacement/refund

The Purchaser will be responsible for paying any prorated costing.

Transfer of Warranty

This warranty may be transferred one (1) time, within the five (5) year period beginning from the date of original consumer purchase by Purchaser, to a subsequent buyer of the property upon which the rail system containing Metal Balusters was originally installed.

Exclusions from Warranty Coverage

This warranty does not cover damage from abnormal or improper use or design, improper product application, accident, alteration, welding, neglect, abuse, lawn care equipment damage, abrasion, harsh chemicals, pool chemicals, or chemicals for ice removal, air pollutants, installation of metal balusters directly on treated (CCA) lumber, improper service or installation or lack of service, or damage caused by flood, fire or acts of God. For product located one (1) mile or less from the coastline, the Term of this limited warranty shall be one (1) year from the date of the original consumer purchase. This limited warranty does not cover Metal Balusters that have come in to direct contact with salt water. Some darkening of the Antique Bronze color is expected to occur over time, and is not a defect or warranty-related issue.

Purchaser is solely responsible for determining the effectiveness, fitness, suitability and safety of the Metal Balusters in connection with its use in any particular application.

Limitations

DISCLAIMER OF WARRANTIES: EXCEPT FOR THE EXPRESS WRITTEN WARRANTY CONTAINED HEREIN, TIMBERTECH MAKES NO OTHER WARRANTIES, GUARANTEES OR INDEMNITIES, WHETHER EXPRESS OR IMPLIED, ARISING BY LAW, COURSE OF DEALING, USAGE OF TRADE, CUSTOM OR OTHERWISE, INCLUDING BUT NOT LIMITED TO THE IMPLIED WARRANTY OF MERCHANTABILITY AND IMPLIED WARRANTY OF FITNESS FOR A PARTICULAR PURPOSE, AND ALL SUCH OTHER WARRANTIES, GUARANTEES AND INDEMNITIES ARE HEREBY DISCLAIMED, OVERRIDDEN AND EXCLUDED FROM THIS TRANSACTION.

Some States do not allow limitations on how long an implied warranty lasts so the above limitation may not apply to you.

LIMITATION OF REMEDIES AND EXCLUSION OF CONSEQUENTIAL AND INCIDENTAL DAMAGES:

TIMBERTECH'S LIABILITIES ARE LIMITED SOLELY AND EXCLUSIVELY TO THE OBLIGATIONS SPECIFICALLY UNDERTAKEN HEREIN, AND UNDER NO CIRCUMSTANCES WILL TIMBERTECH BE LIABLE OR OBLIGATED FOR ANY INCIDENTAL, CONSEQUENTIAL, INDIRECT, SPECIAL, PUNITIVE OR ANY OTHER DAMAGES OF ANY KIND WHATSOEVER (INCLUDING, BUT NOT LIMITED TO, LOST PROFITS, LOST SALES, LOSS OF GOODWILL, USE OF MONEY, USE OF GOODS, STOPPAGE OF WORK, OR IMPAIRMENT OF ASSETS), WHETHER FORESEEABLE OR UNFORESEEABLE, ARISING OUT OF BREACH OR FAILURE OF EXPRESS OR IMPLIED WARRANTY, BREACH OF CONTRACT, FRAUD, MISREPRESENTATION, NEGLIGENCE, STRICT LIABILITY IN TORT OR OTHERWISE, EXCEPT AND ONLY TO THE EXTENT THIS LIMITATION IS SPECIFICALLY PRECLUDED BY APPLICABLE LAW OF MANDATORY APPLICATION. TIMBERTECH'S LIABILITY WITH RESPECT TO DEFECTIVE PRODUCTS SHALL IN NO EVENT EXCEED THE REPLACEMENT OF SUCH PRODUCTS OR REFUND OF THE PURCHASE PRICE, AS DESCRIBED ABOVE.

Some states do not allow the exclusion or limitation of incidental or consequential damages, so the above limitation or exclusion may not apply to you. This warranty gives you specific legal rights, and you may also have other rights that vary from state to state.

Miscellaneous

This writing is understood and intended to be the final expression of the parties' agreement and is a complete and exclusive statement of the terms and conditions with respect thereto, superseding all prior agreements or representations, oral or written, and all other communication between the parties relating to the subject matter of this agreement. This warranty may not be altered or amended except in a written instrument signed by TimberTech and Purchaser or permitted transferee. No agent, employee or any other party is authorized to make any warranty in addition to that made in this agreement and TimberTech shall not be bound by any such statements other than those contained in this warranty.

This warranty is effective for consumer purchases made on or after January 1, 2011.

Copyright © 2012 TimberTech

Every TimberTech product is backed by exceptional customer service and a commitment to quality

Warranty Registration is Easy

- The easiest way to register a warranty is to visit www.timbertech.com and select the Warranty & Care link, then select Register Online.
- You may prefer to fill out the Warranty Card below and mail it to TimberTech, accordingly to the instructions on the card.

Remember, to ensure your product is covered by the TimberTech Warranty it must be installed properly.

TimberTech LTD disclaims any liability or responsibility for the improper installation of this product. The purchaser is solely responsible for compliance with applicable local codes as to the deck's intended use. TimberTech recommends all designs be reviewed by a licensed architect, engineer or local building official before installation. TimberTech maintains a list of physical properties to assist the design professional.

Below is a chart showing which product each warranty covers. You can view warranty details online at www.timbertech.com:

- **Limited 25-Year Residential Warranty / Limited 10-Year Commercial Warranty**
 - Decking:** DockSider, Floorizon, ReliaBoard Plank, ValuPlank, Earthwood, TwinFinish, XLM
 - Railing:** Ornamental Rail, RadianceRail, BuilderRail (excluding all metal baluster components of BuilderRail System), Secure - Mount Post System, ADA Hand Rail System
 - Fencing:** All FenceScape products
 - Accessories:** CONCEALoc, DrySpace
- **Limited 10-Year Warranty for Metal Baluster Components of BuilderRail System**
- **Limited 5-Year Warranty for DeckLites System**

To Make a Claim

To make a claim under either warranty, purchaser or the transferee, must send to TimberTech, within the warranty period referred to above, a description of the claimed defect and proof of purchase. Warranty Information Packets can be obtained from TimberTech.

TimberTech Limited

Attn: Claims Department • 894 Prairie Avenue, Wilmington, Ohio 45177 • Or call 1-800-307-7780

TimberTech Customer:
Please complete this warranty card and mail to:

TimberTech
894 Prairie Avenue
Wilmington, Ohio 45177
Attn: Warranty

This information will help us better serve your needs.

Please return warranty card within 30 days of receipt of product.



Name: _____ Purchase Date: _____
Street Address: _____
City: _____ State/Province: _____ Zip/Postal Code: _____
Country: _____ Phone: _____ : _____

Product Information:

Where was your product purchased? _____
How was your product installed? _____
 Contractor Name: _____ Self-Installed

Warranty Registration: Check the TimberTech product that you purchased:

Decking: Earthwood Evolutions™ Plank ReliaBoard™ Plank Accessories: _____
 Floorizon® Plank XLM® Plank _____
 DockSider™ Plank TwinFinish® Plank

Railing: RadianceRail® Ornamental Rail BuilderRail® Metal Balusters
 RadianceRail® Express Secure-Mount System ADA Hand Rail System

DrySpace™ DeckLites® FenceScape®

Demographic Information: Number of residents in household: _____

Number of household residents in the following age groups:

0-12 13-18 19-27 28-39 40-55 55+

Average household income:

Under \$35,000 \$35,000-50,000 \$50,000-70,000 \$70,000-95,000 \$95,000+

Notes

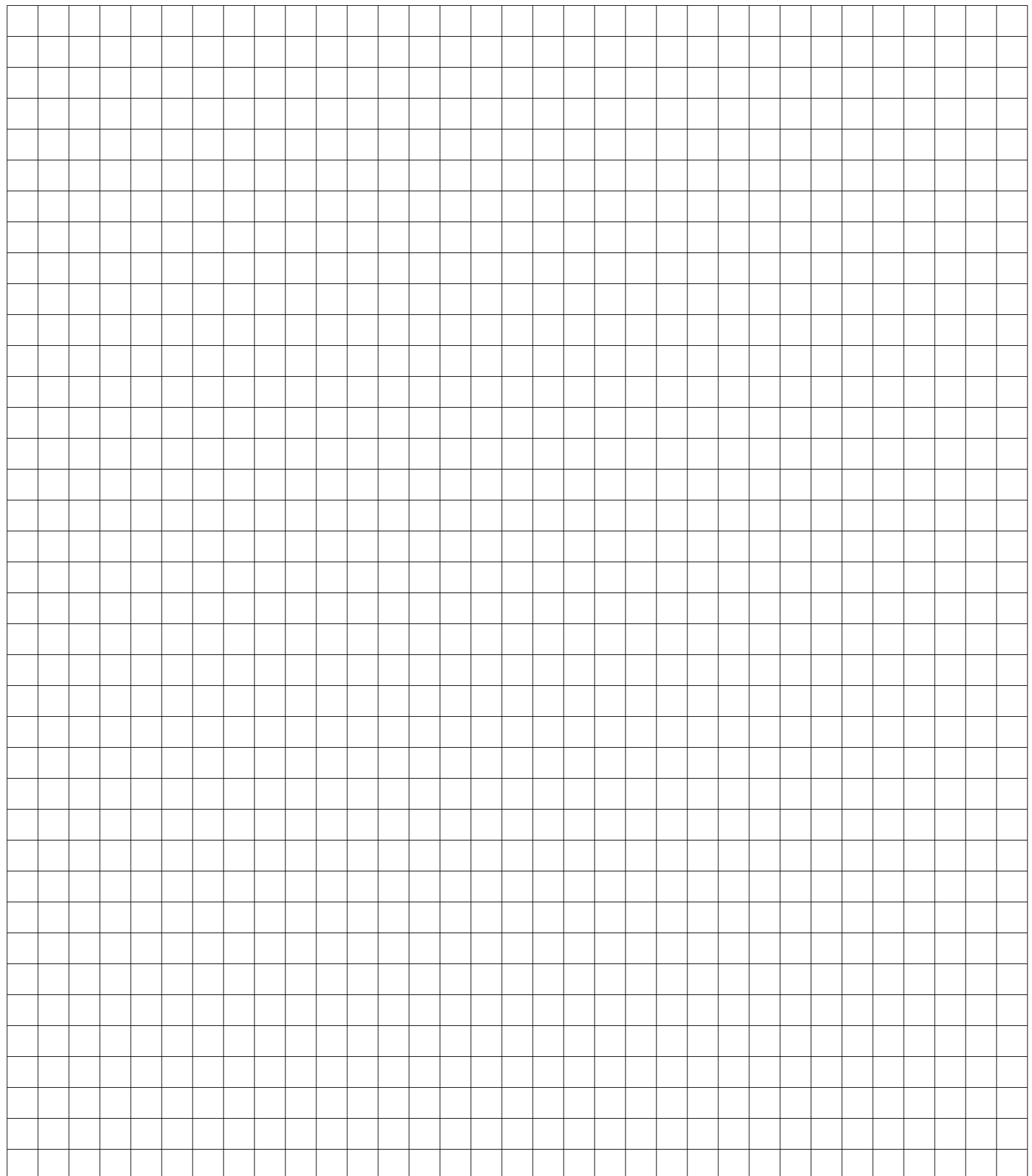

It's not just a deck. It's TimberTech.

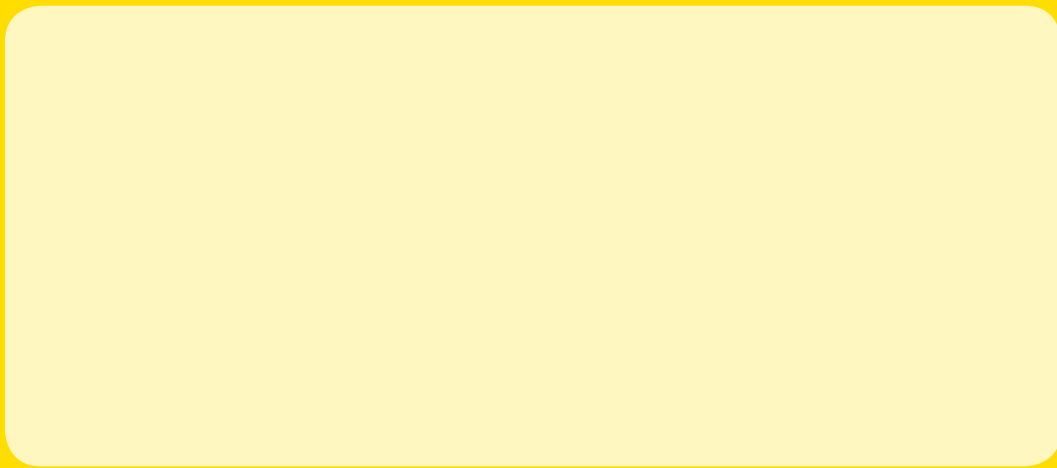

Visit timbertech.com or
call 1-800-307-7780 for more information.